

## TABLE OF CONTENTS

SERIES DB WARRANTY.....	1
FREIGHT CLAIMS .....	2
SERIES DB SPECIFICATIONS .....	3
PACKAGING DETAILS - PREASSEMBLED DOORS.....	13
DOOR LEAF DETAILS - CORE & PREPS.....	14
DOOR LEAF DETAILS - HARDWARE LOCATIONS.....	15
STANDARD DOOR FRAME DETAILS WITH FLUSH SUBFRAME .....	16
STANDARD DOOR FRAME DETAILS WITH OFFSET SUBFRAME.....	17
STANDARD DOOR SUBFRAME DETAILS.....	18
FLUSH SUBFRAME ATTACHMENT DETAILS .....	19
OFFSET SUBFRAME ATTACHMENT DETAILS.....	20
LATCHGUARD DETAILS.....	21
STANDARD-DUTY CLOSER .....	22
MODERATE-DUTY CLOSER .....	23
HEAVY-DUTY CLOSER .....	24
CRASH CHAIN DETAILS .....	25
STANDARD LOCK DETAILS - GRADE 2.....	26
STANDARD LOCK DETAILS - GRADE 1.....	27
DEFAULT GRADE 1 STANDARD-DUTY EXIT DEVICE DETAILS.....	28
FORMATTED, INTERCHANGEABLE CORE (S.F.I.C.) INFORMATION .....	29
MORTISE LEVER LOCK DETAILS .....	30
HINGE DETAILS.....	31
STANDARD FULL-SURFACE CONTINUOUS HINGE .....	32
STANDARD U-SWEEP .....	33
PERIMETER WEATHERSTRIPPING.....	34
STANDARD A.D.A COMPLIANT THRESHOLD .....	35
KICK-PLATE DETAILS .....	36
DOUBLE DOOR DETAILS .....	37

# **EXPI-DOOR® Systems Inc.**

MEMBER OF THE BAY FAMILY OF COMPANIES

## **SERIES DB WARRANTY**

The Series DB door system by EXPI-DOOR® Systems Inc. carries a **limited two year warranty**. See following Tech Data pages for individual warranty information of specific hardware items or accessories. The warranty is to original consumer purchasing the product free of defects in materials, manufacture, or workmanship. The product warranty does not apply if product is damaged by abuse, misuse, or accident. Should the product be otherwise than warranted during this period, EXPI-DOOR Systems Inc. shall repair or replace the product found to be defective. Replace shall mean providing defective material free of charge or an equivalent amount of new product in exchange for product found to be defective. All Labor or other costs of repair or replacement are excluded.

Returned product will not be accepted unless an RMA (return Material authorization) is provided by EXPI-DOOR System Inc. customer service representative. No materials held over 30 days from delivery can be returned. To receive prompt and proper credit please refer to invoice and purchase order number with date product was received. All items being returned must be in restockable condition. Restocking fees on returned stock product may apply, special order products shall not, cannot be returned.

## **FREIGHT CLAIMS**

1. Freight claims are **not** considered a part of the warranty process.
  - a. Once product leaves the EXPI-DOOR® Systems Inc. dock, it becomes the freight carrier and receivers responsibility.
  - b. When the receiver signs the delivery receipt from the driver, the material then becomes the receiver's responsibility.
2. Examine freight before driver leaves and note ANY damage on delivery receipt no matter how small.
  - a. If there is damage noted, please contact EXPI-DOOR® Systems Inc. right away at 920-393-4028. We will work at getting you what you need ASAP.
  - b. If damage is extensive, please refuse freight due to damage contact EXPI-DOOR® Systems Inc. ASAP and replacements will be worked on ASAP.
3. If damages or shortages are noticed any point after the driver departs from the delivery point, the receiver is then solely responsible for replacements.
  - a. If you notice damage after the diver has left you have five days to reach out to EXPI-DOOR® Systems Inc. with pictures to get a hidden freight claim filed.
  - b. The receiver will be responsible for the cost of the replacement, but EXPI-DOOR® Systems Inc. will file a hidden freight claim and will credit that chargeable PO if the carrier honors the hidden freight claim.

We understand how damage can affect your job's progress and EXPI-DOOR® Systems Inc. will do everything in its power to deliver new or replacement product ASAP, but will need the receiver's help to follow the above outline when freight come in to their job site to allow it to go more smoothly.

# SERIES DB SPECIFICATIONS

## A. INTRODUCTION:

- A.1.0 The following information pertains to EXPI-DOOR's current Series DB door offering. We will discuss the specifics of preassembled door systems, as well as knock-down door systems. We will also discuss all hardware components of each system, as well as the creation or grouping of these items.
- A.1.01 All door systems provided by EXPI-DOOR are considered as "medium to heavy-duty commercial" type.
- A.1.02 Our Series DB offering was created specifically to offer a cost-effective product for light- to medium-duty environments. It should also be noted that this product line is similar, but superior to our competitor's standard offering of door systems.

## B. SUBMITTALS:

- B.1.0 For standard orders, where no special, non-stock conditions exist, our clients are encouraged to use the product data included here-in and in the following pages. This includes door and frame gauges, hardware grades, designs and finishes, and any other associated components that apply to the final design and assembly of the product.
- B.1.01 For non-standard orders, and where EXPI-DOOR provided a "specialized product" type quote for non-stock materials, it is required that our client contact the person responsible for that quotation and request a detailed submittal. This will be done at no cost to our client.
- B1.02 Submittals must be approved by a signature from the architect or end-user prior to ordering from EXPI-DOOR. EXPI-DOOR reserves the right to hold any order until the submittal is positively approved by the appropriate entity.

## C. QUALITY ASSURANCE

- C.1.01 EXPI-DOOR products pass through a minimum of three stations. First is a preparation and fabrication station. The second is the assembly station. The third is the final examination and packaging station. After installation of hardware items, each is tested to ensure proper alignment and function. Upon completion, product is inspected by a third-party for final quality appearance.

## D. PRODUCTS and COMPONENTS

- D.1.01 Hinges – All hinges are ANSI 156.1

- A. Ives 5BB1 4.5" x 4.5" NRP 652 (satin chrome plated), standard option.

1. Made with two ball bearing assemblies. Non-removable pin.
2. Certified to ANSI/BHMA A156.1 for performance standards.
3. Meets ANSI/BHMA 156.7 for template hinge dimensions.
4. Steel with steel pin ANSI A8112.
5. UL Classified for windstorm rated assemblies - R37965.
6. UL Listed, 3 hour fire doors.

- B. Hager ECBB1101 4.5" x 4.5" NRP US32D (stainless steel), optional.

1. Made with two ball bearing assemblies. Non-removable pin with button tip and plug.
2. Stainless steel with stainless steel pin ANSI A5112.
3. Complies with NFPA80

- C. Hager BB1191 4.5"X4.5" NRP US26D (satin chrome plated), optional.

1. Made with two ball bearing assemblies. Non-removable pin with button tip and plug.
2. Brass with stainless steel pin ANSI A2112.

- D. Hager BB1199 4.5" X 4.5" NRP US32D heavy-weight hinge (stainless steel), optional.
  - 1. Made with four ball bearing assemblies. Non-removable pin with button tip and plug.
  - 2. Stainless steel with stainless steel pin ANSI A5111.
  - 3. Complies with NFPA80.
- E. Hager continuous hinge 83" 780-157FFUL-83" (Aluminum 6063-TG), 4070 standard option.
  - 1. Option: UL Listed, 1-1/2 hr. metal doors.
  - 2. Option: UL Listed, 3 hr. metal doors. Stainless steel studs (4) required. (Extended lead time.)
- D.1.02 Cylindrical Lockset. Order keyed alike unless specified. Master keying available option. ADA compliant.
  - A. Falcon GR2 W Series Dane 626 Entry
    - 1. Lever standard: Levers are pressure cast zinc (solid levers no inserts) material finished to match mating parts.
    - 2. Rose: Roses are heavy wrought brass or bronze, installed over steel rose inserts which are through-bolted.
    - 3. 6-pin conventional "C" keyway (standard).
    - 4. Small format interchangeable core (S.F.I.C. Optional). (Extended lead time.)
    - 5. Function Options: W511 Entry - ANSI F109, W581 - Storeroom ANSI F86, (lead time), WS61 - Classroom ANSI F84, (lead time), W101- Passage ANSI F75, (lead time), W301 - Privacy - ANSI F76, (lead time),
    - 6. ANSI/BHMA: Certified A156.2, Series 4000, Grade 2.
    - 7. UL/cUL: Listed for 3-hour fire door, A label.
    - 8. CA Fire Code: All levers with a return to door of 1/2" (64 mm) or less comply.
    - 9. Federal: BAA listed.
  - B. Falcon GR1 T Series Dane 626 Entry.
    - 1. Lever Standard: Levers are pressure cast zinc (solid levers no inserts) material finished to match mating parts.
    - 2. Rose: Roses are heavy wrought brass or bronze, installed over steel rose inserts which are through-bolted.
    - 3. 6-pin conventional "C" keyway (standard).
    - 4. Small format interchangeable core (S.F.I.C. Optional). (Extended lead time.)
    - 5. Function Options: T511 Entry - ANSI F109 (standard), T581- Storeroom ANSI F86, (lead time), T561- Classroom ANSI F84, (lead time), T101- Passage ANSI F75, (lead time), T301 - Privacy - ANSI F76, (lead time),
    - 6. ANSI/BHMA: Meets or exceeds A156.2, Series 4000, Grade 1 strength and operational requirements.
    - 7. UL/cUL: Listed for 3-hour fire door, A label.
    - 8. CA Fire Code: All levers with a return to door of 1/2" (64 mm) or less comply.
    - 9. Federal: BAA listed.

D.1.03 Mortise locks. Order keyed alike unless specified. Master keying available option. ADA compliant.

A. Falcon GR1 Mortise MA Series Dane 626.

1. Dead bolt: 1" throw, stainless steel with two 3/16" diameter hardened steel, free-turning, saw-resistant roller.
2. Faceplates: (armored front) 1 1/4" x 8" brass or stainless steel adjustable for door bevel. Reinforced by heavy gauge steel with stabilizing ribs.
3. Strike: Brass or stainless steel. Meets ANSI A115.1 for frame preparation. Strike is non-handed
4. 6-pin conventional "C" keyway (standard).
5. Small format interchangeable core (S.F.I.C. Optional).
6. Function Options: MA571 Dormitory -ANSI: F13 (Standard), MA581 Storeroom ANSI: F07 (lead time). MA561 - Classroom ANSI F05, (lead time).
7. ANSI/BHMA: L/LV9000: ANSI/BHMA A156.13-2017 Series 1000, Grade 1.
8. UL/cUL locksets comply with UL10B - neutral pressure and UL10C/UBC 7-2 - positive pressure testing requirements. All locks shall be UL listed for 3 hour fire door.
9. CA Fire Code: All levers with a return to door of 1/2" (64 mm) or less comply.
10. FL Building Code: Miami-Dade NOA and Florida Building Commission listings.
11. Federal: BAA compliant, all function.

D.1.04 Exit devices (panic bar).

A. Hager 4701 Rim 36" Alum: Exterior key-in-lever trim covers stock hollow metal doors with 161 cutouts if needed.

1. ANSI A156.3, Grade 1, Exit device for single doors and double doors with mullion, UL listed exit device hardware option. Hex key dogging standard for non-fire rated doors. Order keyed alike unless specified. Master keying available option.
  - a. UL305 listed for panic hardware.
  - b. UL/cUL listed for up to 3 hours for "A" labeled doors.
  - c. UL10C positive pressure rated.
  - d. UL10B neutral pressure rated.
  - e. Warnock Hersey listed for up to 3 hours with fire rated removable mullion.
  - f. Complies with ANSI 117.1 for accessible buildings and facilities.

B. 47KE ALM Key-In-Lever: Entrance Grade 1: steel body and zinc handle. Order keyed alike unless specified. Master keying available option. ADA compliant.

1. Certifications: Complies with ANSI A117.1 for accessible buildings and facilities (levers only).
3. 6-pin conventional "C" keyway (standard).
4. Small format interchangeable core (S.F.I.C. optional.) (Extended lead time.)
5. Function 08: Key-in-lever entrance by trim (key locks or unlocks trim)
  - a. Certifications: Complies with ANSI A117.1 for accessible buildings and facilities (levers only).
  - b. E.O. = Exit only - no exterior trim.
6. Door leaf 161 lock preparation does not have reinforcement for exit device tail (hinge side), therefore it is recommend using thru-bolt to hold tail of device into place if this prep is used for exit device hardware.

D.1.05 Closers – surface-mounted – ANSI A156.4 – Grade 1. All Falcon closers are standard as ADA compliant with less than 5 lbs. of opening force. Falcon closers are available with hold-open as an option. All Falcon closers are single piece cast aluminum cylinder assemblies.

A. Falcon SC61.

1. Light- to medium-duty applications.
2. Adjustable spring size 1-5.
3. Heat-treated pinion and steel piston.
4. UL10C and UBC 7-2 (1997).

B. Falcon SC81.

1. Medium-duty application.
2. Adjustable spring size 1-6.
3. 1 1/4" diameter heat treated steel piston.
4. Double heat-treated pinion.
5. UL10C and UBC 7-2 (1997).

C. Falcon SC71.

1. Busy commercial and institutional applications.
2. Adjustable spring size 1-6.
3. 1 1/2" diameter heat treated steel piston.
4. Double heat-treated pinion.
5. UL10C and UBC 7-2 (1997).

D.1.06 Keyways / Cylinders.

- A. Standard: Round, 6-pin type – when two or more doors are present per order, keyways shall be keyed alike by EXPI-DOOR.
- B. Formatted (optional): Figure-8 type, small format interchangeable or full-size interchangeable type (please choose). Each core, or keyway shall be provided with (1) change, and (1) operating key. Change keys are only for the removal/insertion of the core. Operating keys are only for locking and unlocking the keyway.

D.1.07 Accessories.

A. Latch guards.

1. Cylindrical or rose trim.
  - a. Non-handed.
  - b. 3" x 11" (76mm x 279mm).
  - c. For use on 1-3/4" (45mm) doors.
  - d. For use with cylindrical locksets with 2-3/4" (70mm) backset & exit device rose trims.
  - e. 12GA stainless steel (US32D).
  - f. Two (2) 5/16"-18 x 1-1/2" carriage bolts with 5/16"-18 x 3/4" sex nuts.

2. Mortise or escutcheon trim.
  - a. Non-handed.
  - b. 3" x 11" (76mm x 279mm).
  - c. For use on 1-3/4" (45mm) doors.
  - d. For use with mortise locksets with 2-3/4" (70mm) backset & exit device with escutcheon trim.
  - e. 12GA stainless steel (US32D).
  - f. Two (2) 5/16"-18 x 1-1/2" carriage bolts with 5/16"-18 x 3/4" sex nuts.
- B. Crash chain - certifications: Meets ANSI A156.16 for L02231. Tear resistant grey EDPM rubber with UV protection cover.
  1. 440 pound load strength.
  2. Designed for full size exterior doors.
  3. Base Plate: 1-1/2" x 1-1/2" (38 x 38 mm).
  4. Materials: Chrome plated zinc alloy base with welded galvanized steel chain.
  5. Finish: US26D.
  6. Fasteners: Ten (10) #8 x 1" FPHSMS.
  7. Length: 30 1/2" (775 mm).
- C. Kick plate - Certification: Meets ANSI A156.6 for J101 metal armor plate, J102 metal kick plate.
  1. UL listed (must specify if UL stamp is needed). Labeling shall not be required where top of protection plate is not more than 16" above the bottom of the door (NFPA 80).
  2. Gauge: 0.050" (1 mm).
  3. Material: Stainless steel.
  4. Finishes: US32D.
  5. Bevel: - 4 edges.
  6. Furnish item #, height, width, and finish (i.e., 190S - 8" x \_\_, US32D).
- D.1.08 Sweeps.
  - A. NGP 331 Door bottom sweep.
    1. Designed for hollow metal doors with inverted bottom channel.
    2. Rigid black polypropylene with flexible TPV fins.
    3. Installs at center line of door leaf.
  - B. NGP 101V Door Bottom Sweep (Optional) - Mill Aluminum Finish. Gray Vinyl. Screw holes slotted for adjustment. Exterior Doors inward swing application.
    1. Certified by UL to CAN/ULC-S104 and ANSI/UL10B.
    2. Positive Pressure - Certified by UL to ANSI/UL10C.
    3. Air Infiltration Tested to ASTM E283.



## D.1.09 Weatherstripping.

- A. NGP 5050C Charcoal weatherseal, standard - self-adhesive silicone fire and smoke seal.
  - 1. Certified by UL to CAN/ULC-S104 and ANSI/UL10B.
  - 2. Positive pressure - certified by UL to ANSI/UL10C.
  - 3. Air Infiltration Tested to ASTM E283.
  - 4. Acoustical tested to ASTM E90.
  - 5. Smoke & draft control gasketing.
    - a. Certified by UL to ANSI/UL10C and ANSI/UL1784 Category 'H'.
- B. NGP 155V Gray vinyl weatherseal, optional - mill aluminum finish. Gray vinyl. Screw holes slotted for adjustment. Exterior doors inward swing application.
  - 1. Certified by UL to CAN/ULC-S104 and ANSI/UL10B.
  - 2. Positive pressure - certified by UL to ANSI/UL10C.
  - 3. Air infiltration tested to ASTM E283.

## D.1.10 Thresholds &amp; spreader bars.

- A. EXPI-DOOR® Systems 5-3/4" depth to match door jambs, saddle type.
  - 1. Comes notched and attached to jambs with #8 x 3/4" fastener.
  - 2. Anchored with 1/4" x 2" flat head Sleeve Anchor.
  - 3. ADA compliant. Barrier-free thresholds meet the requirements of the ADA Standard for Accessible Design and ICC/ANSI A117.1 Accessible and Usable Buildings and Facilities.
- B. Spreader bar, optional.
  - 1. Used on preassembled door systems when standard threshold is not required or when alternate thresholds are used. Tack welded, non door side, base of jamb.
  - 2. Taken off prior to threshold installation by knocking off with hammer. Tack weld may need to be filed/ground down before threshold installation.
- C. NGP 896V Threshold, optional.
  - 1. 5" Wide, 1/2" tall, 0.105 wall thickness and need to notch to fit jamb. Comes in mill finish; vinyl bumper seal is gray.
  - 2. Anchored with 1/4" x 2" flat head sleeve anchor.
  - 3. Used for exterior door applications that door swings into building.
  - 4. ADA compliant. Barrier-free thresholds meet the requirements of the ADA Standard for Accessible Design and ICC/ANSI A117.1 Accessible and Usable Buildings and Facilities.

## D.1.11 Lite kit

- A. Certified by UL to CAN/ULC-S104 and ANSI/UL10B, complies with NFPA 80 and NFPA 252 for application to hollow metal fire doors rated up to 3 hrs.
- B. Positive pressure - Certified by UL to ANSI/UL10C. Complies with IBC, NFPA 80 and NFPA 252 for application to hollow metal fire doors rated up to 3 hrs.
- C. Location option: Non-ADA height unless specified.
- D. Standard kit glass thickness: 1/4" non-insulated glass or 1" insulated glass.
- E. 18 gauge. A40 Galvanneal steel. Mitered and welded corners. Welded reinforcing clips at corners. Counter-sunk mounting screw-holes. #8 Phillips head SMS.

- F. Color option: Gray Primer (GPZ), EXPI-DOOR® White or EXPI-DOOR® Antique Bronze (powder coat finish).
- G. Designed for 1-3/4" thick doors manufactured within door industry tolerance of +/- 1/16" Minimum 18G galv. "U" Channel tack welded inside door leaf prior to lite kit installation for all fire-rated doors.
- H. Kit sizes (stock sizes below only - custom sizes available by request).
1. 10" x 10" x 1/4" with UL mark. (Actual Kit: 9.75" x 9.75" x 1/4"). Exposed glass: 7-3/4" x 7-3/4"
  2. 9" x 30" x 1/4" with UL mark. (Actual Kit: 8.75" x 29.75" x 1/4"). Exposed glass: 6-3/4" x 27-3/4"
  3. 24" x 30" x 1/4" with UL mark. (Actual Kit: 23.75" x 29.75" x 1/4"). Exposed glass: 21-3/4" x 27-3/4"
  4. 9" x 30" x 1" with UL mark. (Actual Kit: 8.75" x 29.75" x 1"). Exposed glass: 6-3/4" x 27-3/4"
  5. 24" x 30" x 1" with UL mark. (Actual Kit: 23.75" x 29.75" x 1"). Exposed glass: 21-3/4" x 27-3/4"
- I. Glazing tape: Medium density closed-cell polyvinyl chloride foam, coated both sides with an aggressive pressure-sensitive adhesive.
1. Absorbs shocks, cushions, deadens sound and eliminates excess vibration. Insulates against temperature. Effectively functions as a thermal break and insulator. Maintains a seal in high movement joints.
  2. Black color standard.
- J. Caulk.
1. Non-rated doors: Solar Seal clear caulk, standard - exterior door side of lite kit.
  2. Fire-rated doors: Dap 100% Silicone clear caulk, standard - exterior door side of lite kit.
- K. Glass types & sizes (stock material below only - other glass types available by request).
1. 1/4" clear tempered safety glass.
    - a. 9" x 30" x 1/4" (Actual glass: 7-11/16" x 28-11/16" x 1/4").
    - b. 24" x 30" x 1/4" (Actual glass: 22-11/16" x 28-11/16" x 1/4").
  2. 1" insulated clear tempered safety glass (comes with breather tube).
    - c. 9" x 30" x 1" (Actual glass: 7-11/16" x 28-11/16" x 1").
    - d. 24" x 30" x 1" (Actual glass: 22-11/16" x 28-11/16" x 1").
  3. 1/4" wire non-tempered glass, standard - fire-rated options. (Wire glass is not safety glass). Authority Having Jurisdiction (AHJ) approval for wire glass recommended for all projects.
    - a. 10" x 10" x 1/4" with UL watermark (90 minute rated).
    - b. 9" x 30" x 1/4" with UL watermark (45 minute rated).
    - c. 24" x 30" x 1/4" with UL watermark (45 minute rated).
  4. 3/16" Pyran glass. (special order)
    - a. 9" X 30" X 3/16" Pyran "F" Filmed Firelite Kit (90 minute rated).
    - b. 24" X 30" X 3/16" Pyran "F" Filmed Firelite Kit (90 minute rated).
    - c. 10" X 10" X 3/16" Pyran "F" Filmed Firelite Kit (3hr rated).

D.1.12 Warranty

A. Door & Frame Assembly (before hardware)	6 Years
B. Falcon Closers	10 Years
C. Standard EXPI Hinges	1 Year
D. HAGER Exit Devices	3 Years from EXPI-DOOR or 2 years more from factory
E. Falcon Mortise Locks	10 Years
F. Falcon Cylindrical Locks & Deadbolts	3 Years (5 years factory)

E. DOORS, FRAMES and SUBFRAME

E.1.01 Door leaves, referred to as "HM" [Hollow Metal]:

- A. Gauge: 18 standard (20 gauge available).
- B. Steel: A40 galvanized quality carbon steel.
- C. Paint: White or bronze, baked-on primer paint, applied per ANSI A250.10.
  - 1. Salt Spray Test, 120 Hours, ASTM B117.
  - 2. Condensation, 240 Hours, ASTM D4585-1992.
  - 3. Impact Test, Gardner Direct 20 in. lbs. w/ ½" ball.
  - 4. Adhesion, ASTM D3359.
- D. Core: Polyurethane
  - 1. U-Value Per ASTM C1363 = 0.38 (old method ASTM C518 = 0.10).
  - 2. R-Value Per ASTM C1363 = 2.63 (old method ASTM C518 = 10.2).
- E. Construction per ANSI A250.8, 1998, hardware reinforcements per ANSI 250.6-1997, and hardware locations per ANSI/DHI A115.
  - 1. Flush, welded-in top channel (rail) shall be 14 gauge.
  - 2. Inverted, welded-in bottom channel (rail) shall be 14 gauge.
  - 3. Closer reinforcement "tube" of 14 gauge shall be inserted prior to insertion of core and prior to final joining of face sheets.
  - 4. Prepared @ lock stile for mortise lock, Gov. 86, ANSI A115.1
  - 5. Prepared @ lock stile for cylindrical lock, Gov. 161, ANSI 115.2
  - 6. Reinforced only @ lock & hinge stile for rim or mortise exit device w/ 14 gauge "tube" prior to insertion of core and prior to final joining of face sheets.
  - 7. 7 Gauge, prepared @ hinge edge for 1 ½ pair standard weight 4.5" high mortised hinges. Shall be provided with one of two kinds of handing plates dependent on standard or heavy-weight hinges.

E.1.02 Door frames, referred to as "HM" [Hollow Metal].

- A. Material: Shall be of high quality carbon steel, A40 galvanized, 16 gauge.
- B. Frame finishes shall consist of baked-on tinted primer per ANSI A250.10 in either white or bronze. Primer shall also consist of zinc-based, rust-inhibitive properties. This finish can be painted over in the field by others.

- C. Reinforcements and preparations.
  1. Strike prep shall be 4 7/8" high, ASA. Strike prep shall be filled, or covered with a filler plate in the rim panic (exit) device applications.
  2. Hinge preparations shall be of 7 gauge steel. Frames shall consist of 1 ½ pair, fully-mortised, 4.5" high, set-up for standard-weight hinges, with optional heavy-weight hinge set-up.
- D. Attachment of threshold: EXPI-DOOR will attach the standard threshold to the frames to create a fully preassembled unit. This is accomplished by inserting (2) self-drilling, self-tapping TEK hex head screws into the reverse of each jamb, and into the fluted channels on the under-side of the threshold. All "special" thresholds do not have this capability and will be shipped loose assembly.
- E. Corner connections.
  1. **\*\*Standard\*\***: Mitered each end of header and top of each jamb. Slot-and-tab connection then back-welded by EXPI-DOOR before final assembly. Covers fire-rated applications.

## F. ANCHORAGE

### F.1.01 C-Channel.

- A. Subframes: 7", 8", 8.5", 10" or 11.5" galvanized 16 gauge (14 gauge for heavier doors) subframes w/ 12 gauge galvanized girt & base clip anchors. Includes all TEK fasteners and zinc plated concrete sleeve anchors. When jamb extensions are required to allow the door subframes to reach an additional or higher than usual first girt, extensions are provided and made of same material. Each extension channel will reach to a recommended maximum height of 12'-0" AFF. The width or depth of these extension pieces shall be ¼" less than the over-all subframe, or girt, depth (over-all width).
- B. Full height masonry, including (8) wire anchors, 1/8" diameter wire, zinc plated. For use in new block wall type.
- C. Partial height masonry, including subframe w/ 12 gauge galv. girt & base clip anchors from top of stem wall (wainscot) to girt. bottom shall be equipped with either wire anchors, or existing masonry application anchors (jamb drilled & dimpled w/ "hat-spacers" welded in).
- D. Existing opening application, including dimpled jambs (4 per jamb) on top of stops, and preferred anchor to attach to existing wall type. Choose one of the following.
  1. Self-drilling, self-tapping, ¼" diameter, zinc plated, 4" length, #4 Phillips driver.
  2. Expandable concrete sleeve anchor, zinc plated – prime painted Phillips head, 3/8" diameter, 5" length, #4 Phillips driver.
  3. Wood screw, ¼" diameter, 4" length, zinc plated, #4 Phillips Driver.
  4. Threaded-rod, 3/8" diameter, 4" length, zinc plated – prime painted Phillips head, w/ star washer and lock-nut, #4 Phillips driver.
  5. Fully-threaded hanger bolt x 4-1/2" length, zinc plated – prime painted Phillips head, #4 Phillips Driver (for existing wood stud applications).

### F.1.02 Jamb insulation.

- A. **\*\*All jambs shall be filled full with "batt" or fiberglass insulation.**

## G. SWING TYPE

- G.101. Customer is to choose from the below chart at time of order confirmation or prior to submitting a purchase order to EXPI-DOOR.

**Description Key:**

Single Door "AI" Swing (LH) Exterior door  
 Single Door "AI" Swing (LH) Interior door

Double Door "CI" Swing (LH active, RH inactive) Exterior door  
 Double Door "CI" Swing (LH active, RH inactive) Interior door

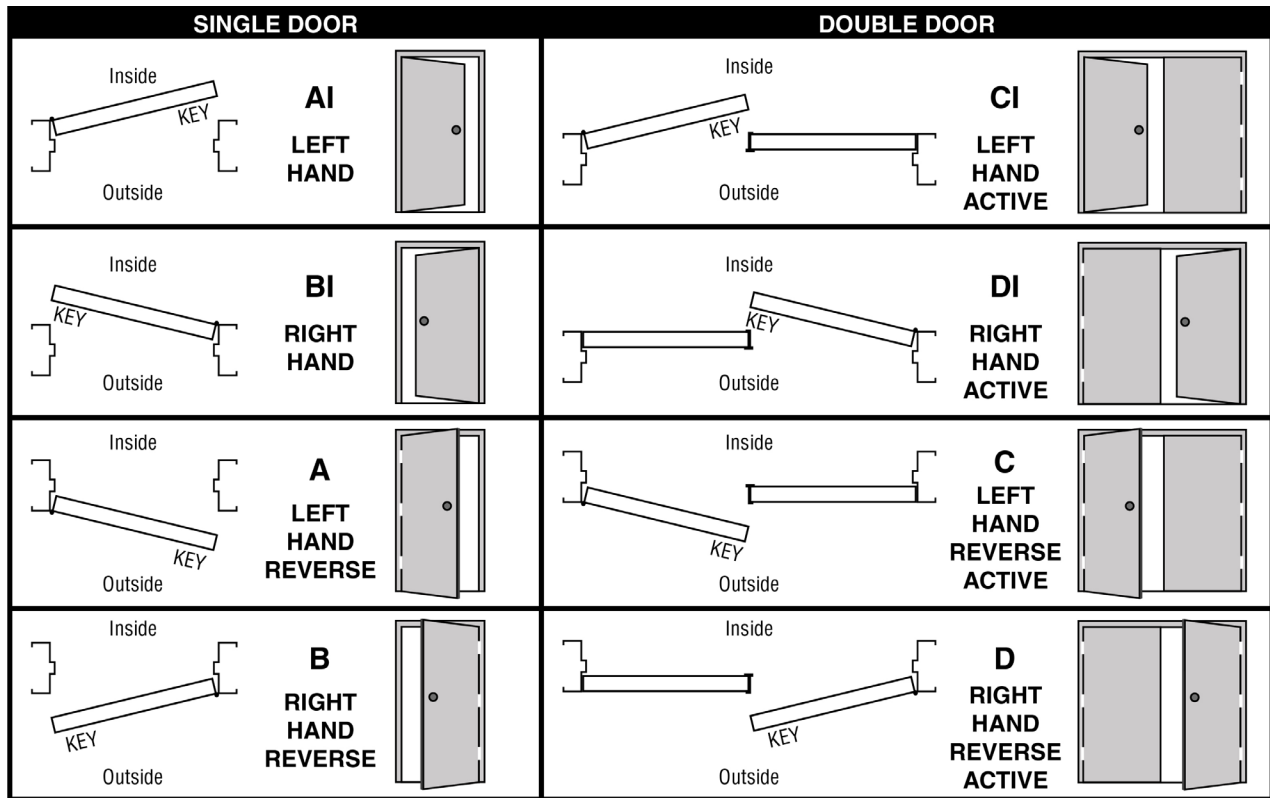

Single Door "A" Swing (LHR)  
 Single Door "BI" Swing (RH) Exterior door  
 Single Door "BI" Swing (RH) Interior door  
 Single Door "B" Swing (RHR)

Double Door "C" Swing (LHR active, RHR inactive)  
 Double Door "DI" Swing (RH active, LH inactive) Exterior door  
 Double Door "DI" Swing (RH active, LH inactive) Interior door  
 Double Door "D" Swing (RHR active, LHR inactive)

Double doors with one active door and one inactive door have "Z" astragal on inactive door standard.

Above noted "interior door" will have threshold and weather-strip unless specified something different.

Above noted "exterior door" will have spreader bar with bumper threshold (shipped loose), drip sweep, concealed sweep, stick on weather-strip and aluminum weather-strip.

Double door C & D both active with mullion: Standard with (2) exit device with lever exterior lock trim or optional exit only (no exterior lock trim).

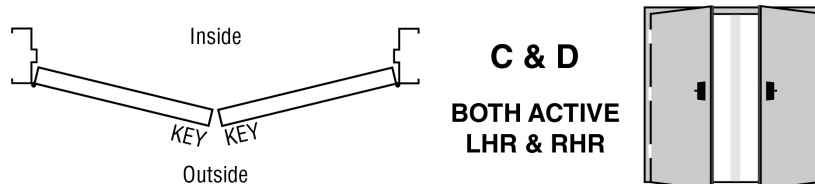

# PACKAGING DETAILS - PREASSEMBLED DOORS

Single door loaded on a 4'x8' pallet, and fastened down through C-channel subframe to 1-3/4" outer runner of pallet. Each door is then stacked and fastened to the door below through C-channel subframe with self driller fastener. Up to 4 doors per pallet can be stacked. A lid is created from 2x4's and OSB and set on top of top door. End caps are then fastened to each girt and base clip and into the ends of the 2x4's of the lid. Side panels are attached to pallet runners at the bottom and to the runners of the "lid".

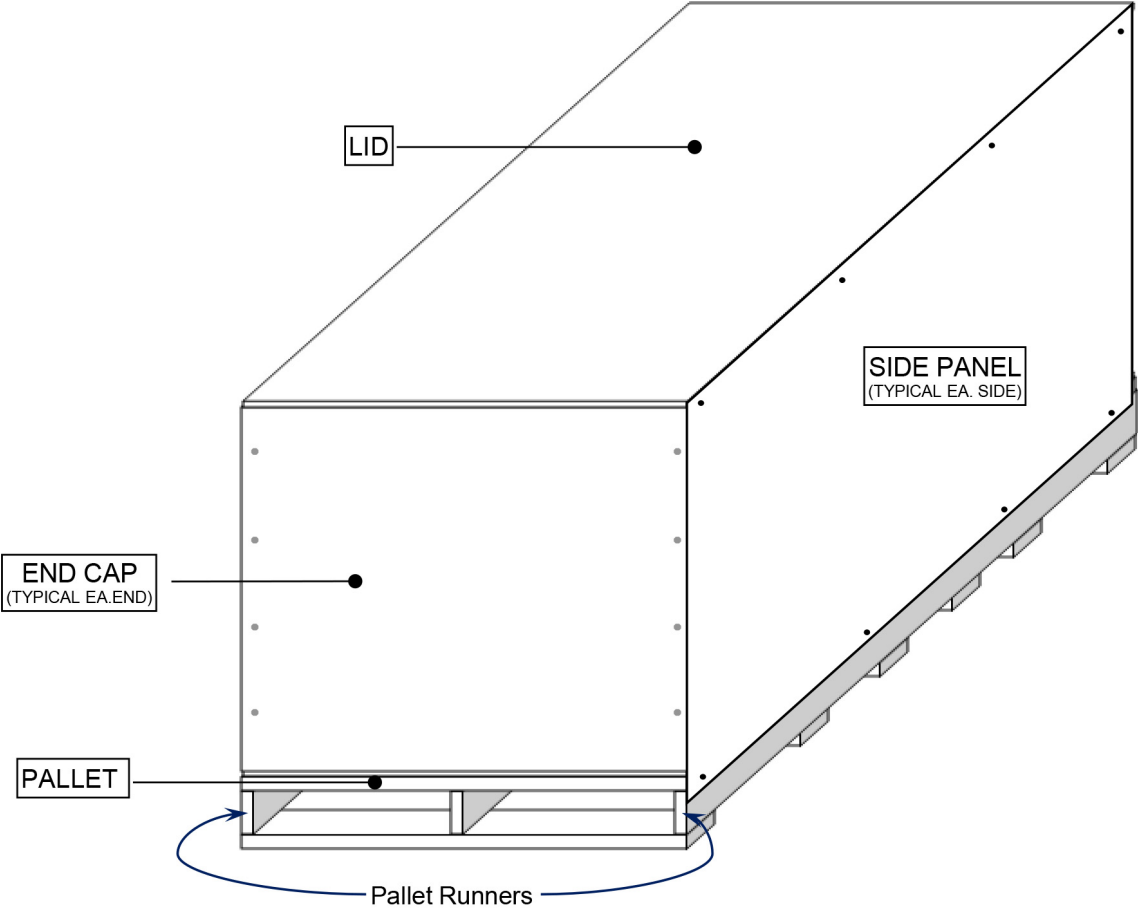

Doors that do not receive subframes, such as Masonry Anchor Doors or Stud Wall Anchor Doors, shall be set on appropriate blocking between each door to create appropriate space between lockset and door leaf of the door above. Sides, ends, and top are all covered with OSB or plywood for a completely boxed product.

# DOOR LEAF DETAILS - CORE & PREPS

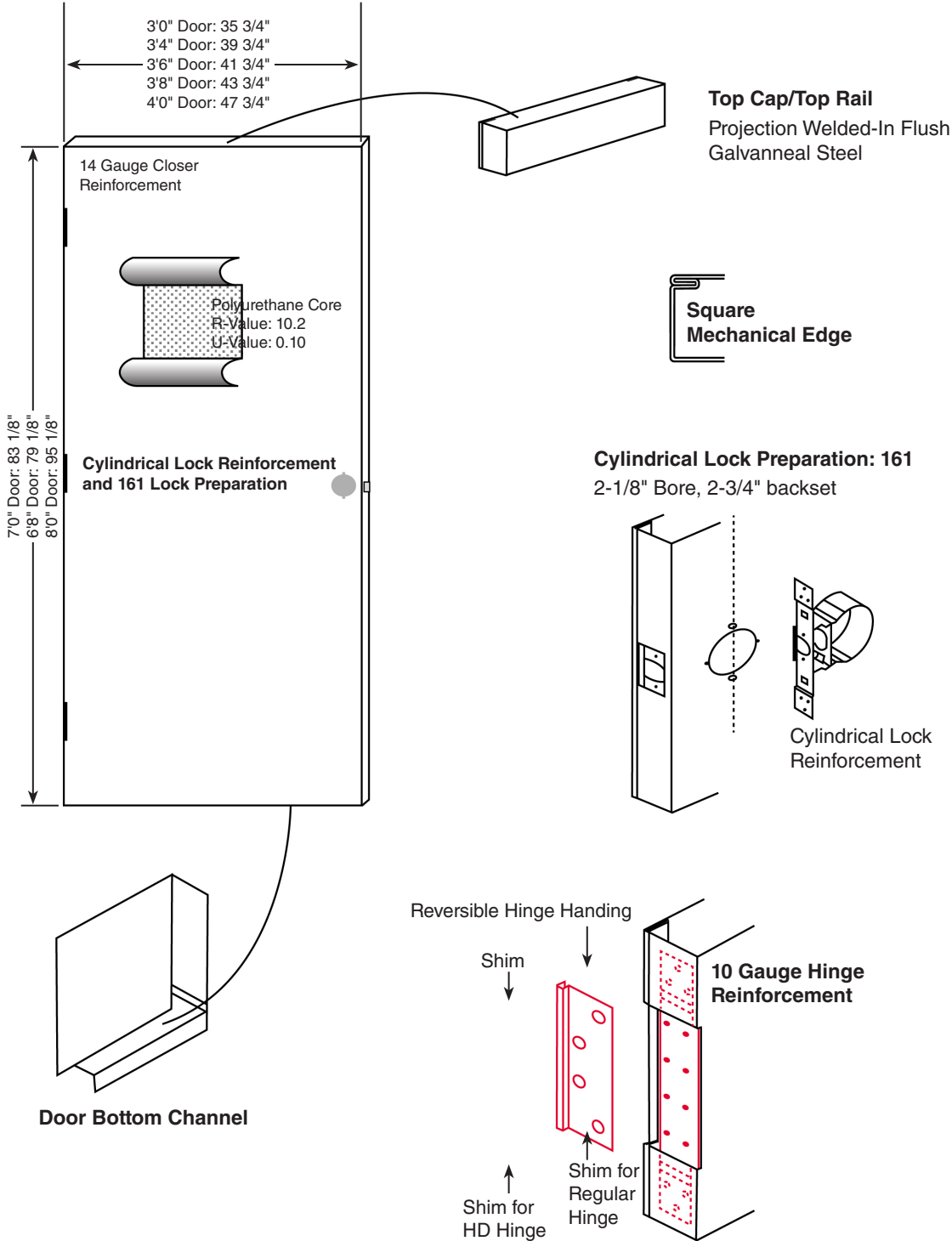

# DOOR LEAF DETAILS - HARDWARE LOCATIONS

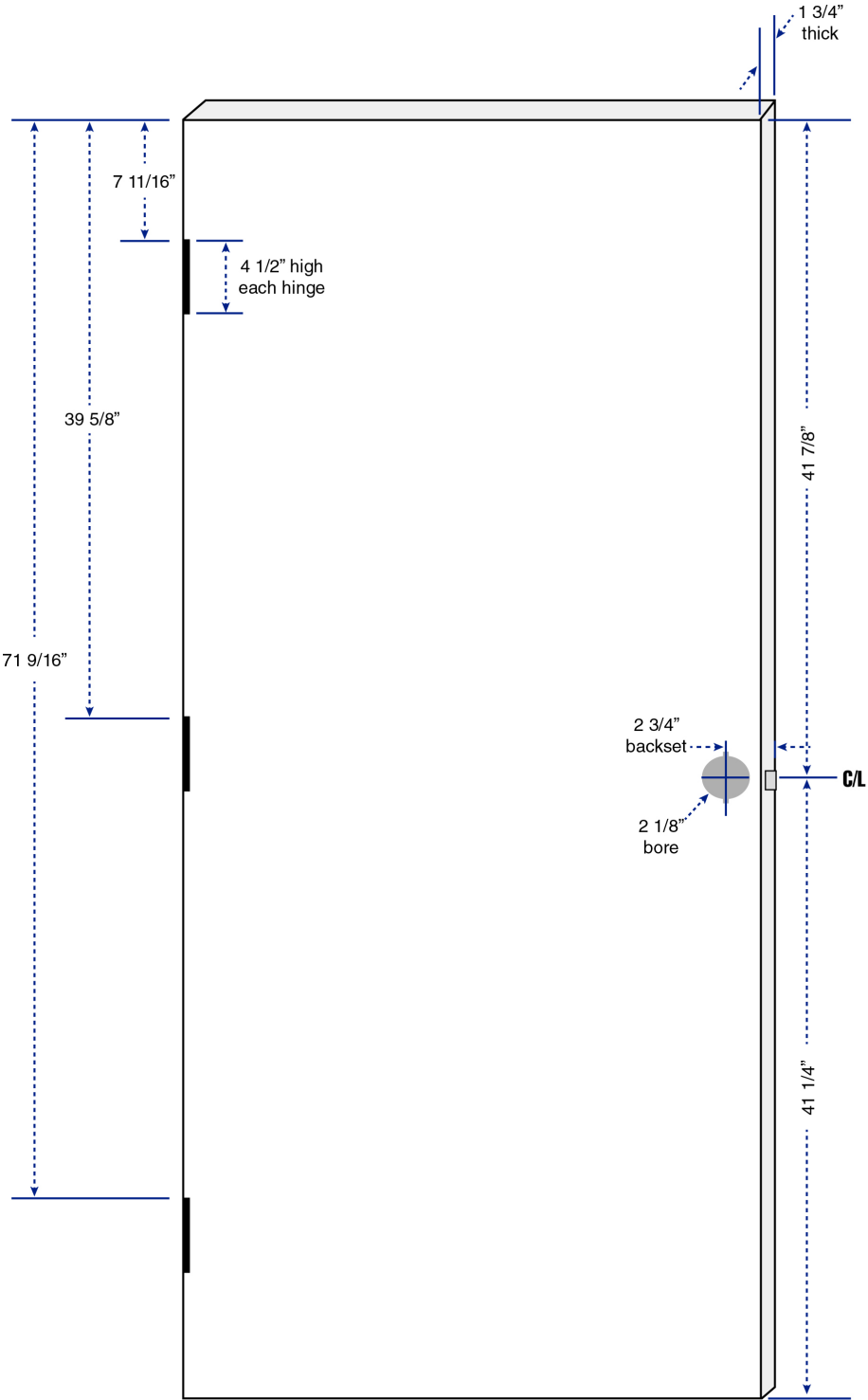



STANDARD DOOR FRAME DETAILS WITH FLUSH SUBFRAME

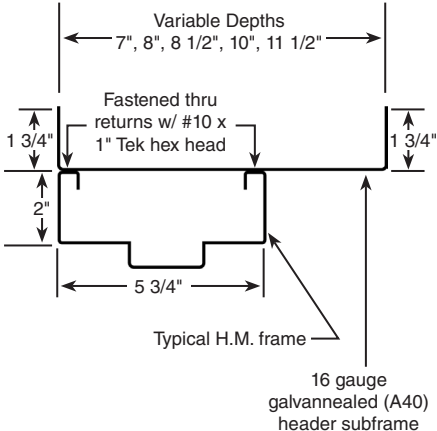
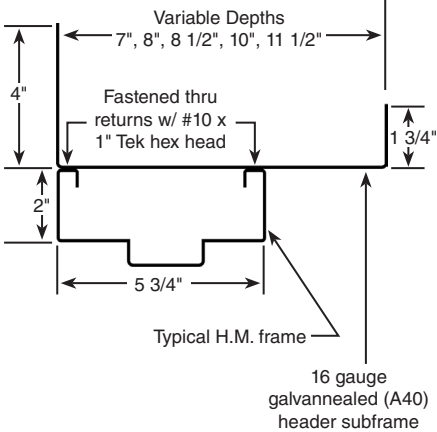
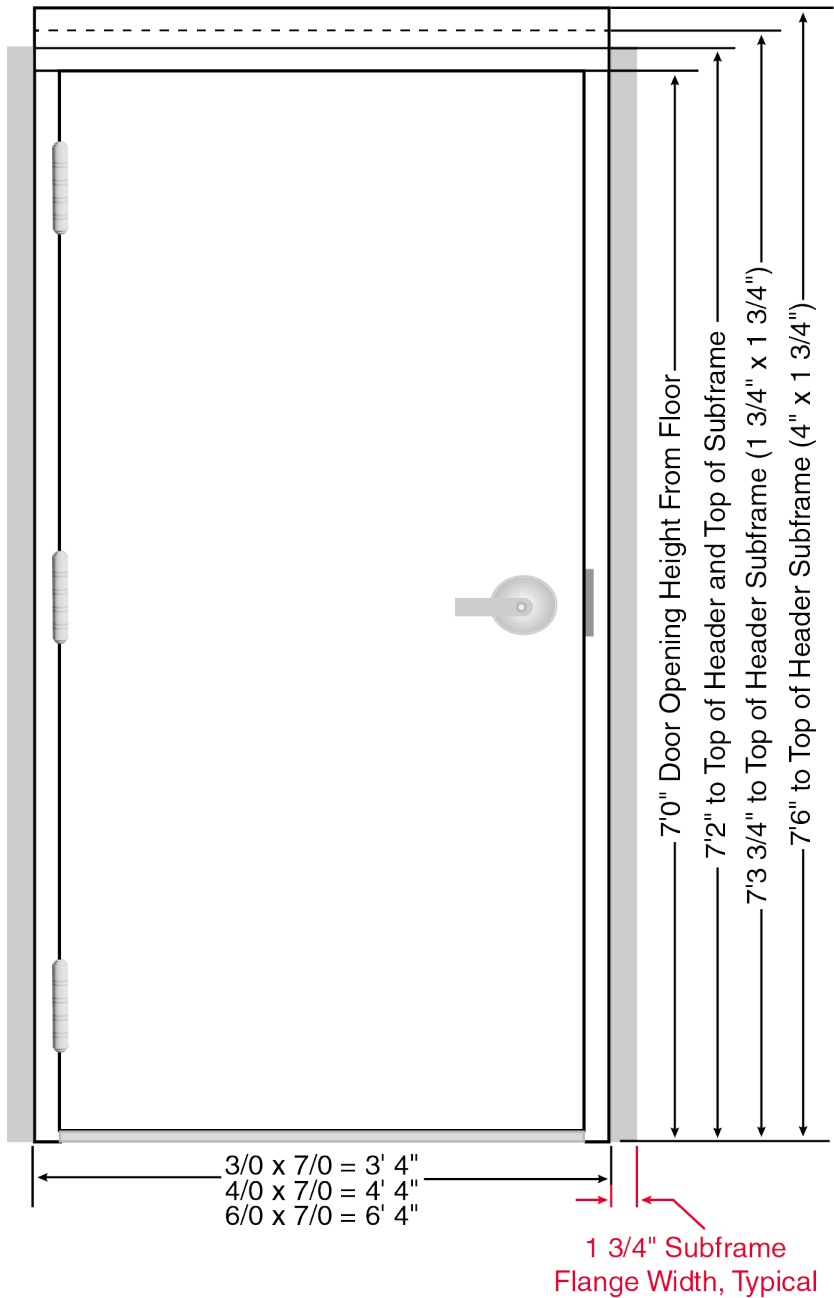

Typical Jamb Header, Strike & Hinge

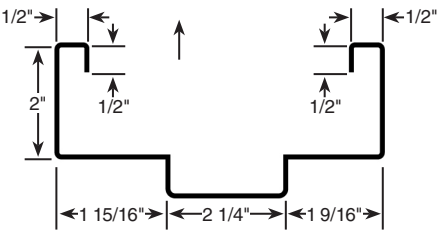

STANDARD DOOR FRAME DETAILS WITH OFFSET SUBFRAME

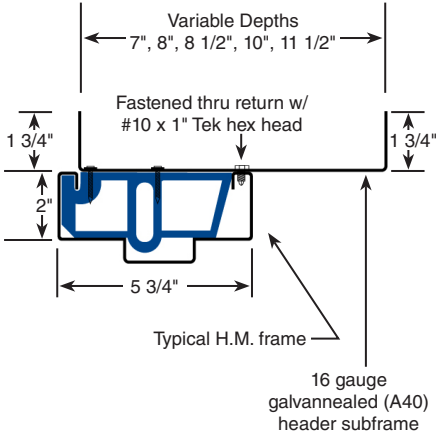
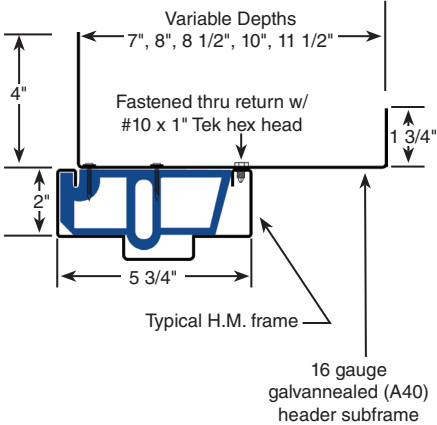
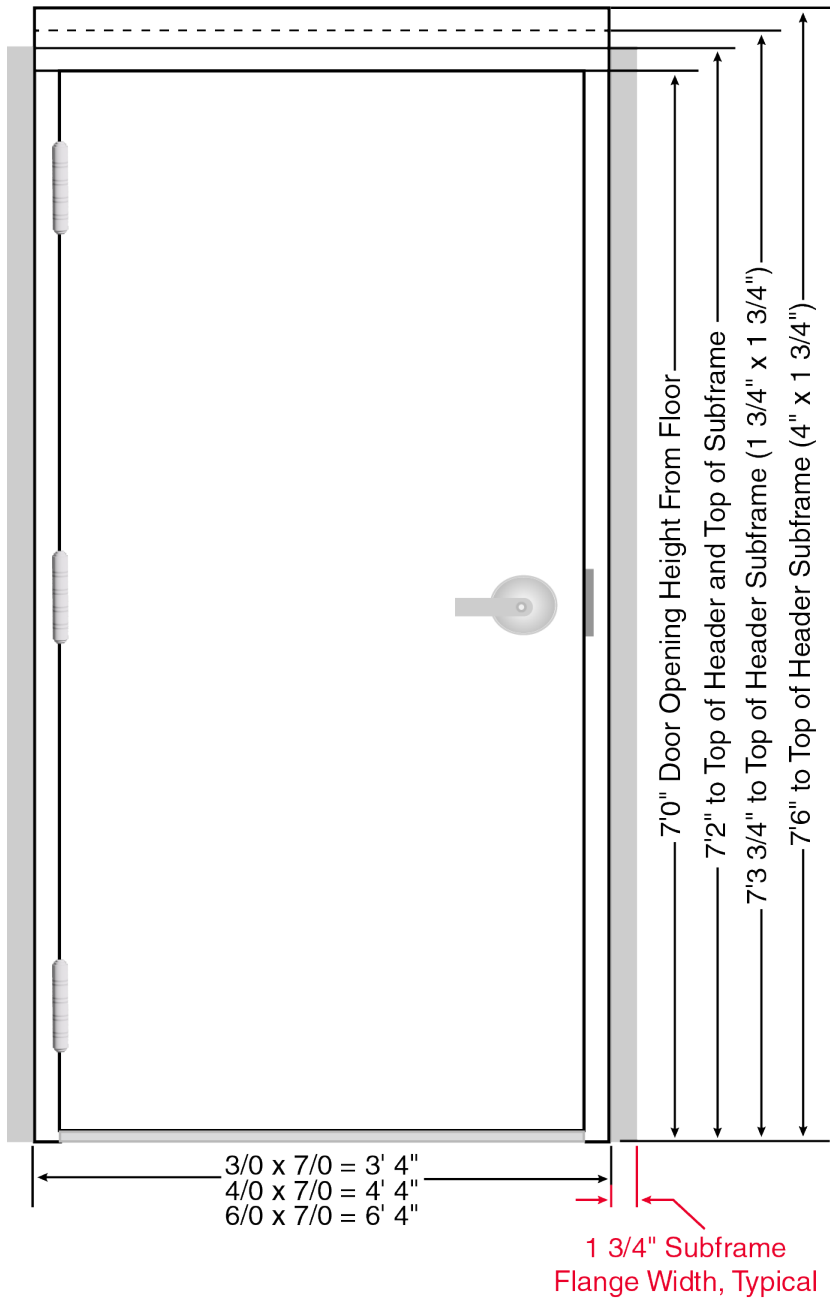

Typical Jamb Header, Strike & Hinge

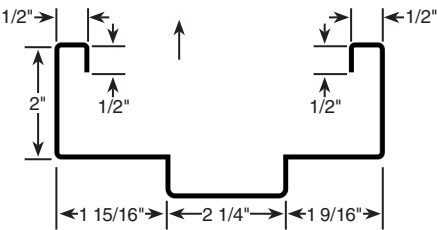

# STANDARD DOOR SUBFRAME DETAILS

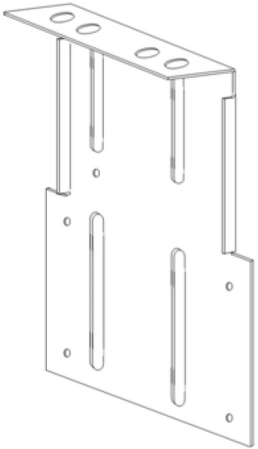

**GIRT ANCHOR (L-CLIP)**  
 12 Gauge galvanized  
 5 3/4" wide x 9 1/2" long

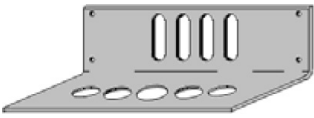

**BASE ANCHOR (L-CLIP)**  
 12 Gauge galvanized  
 5 3/4" wide x 2" high

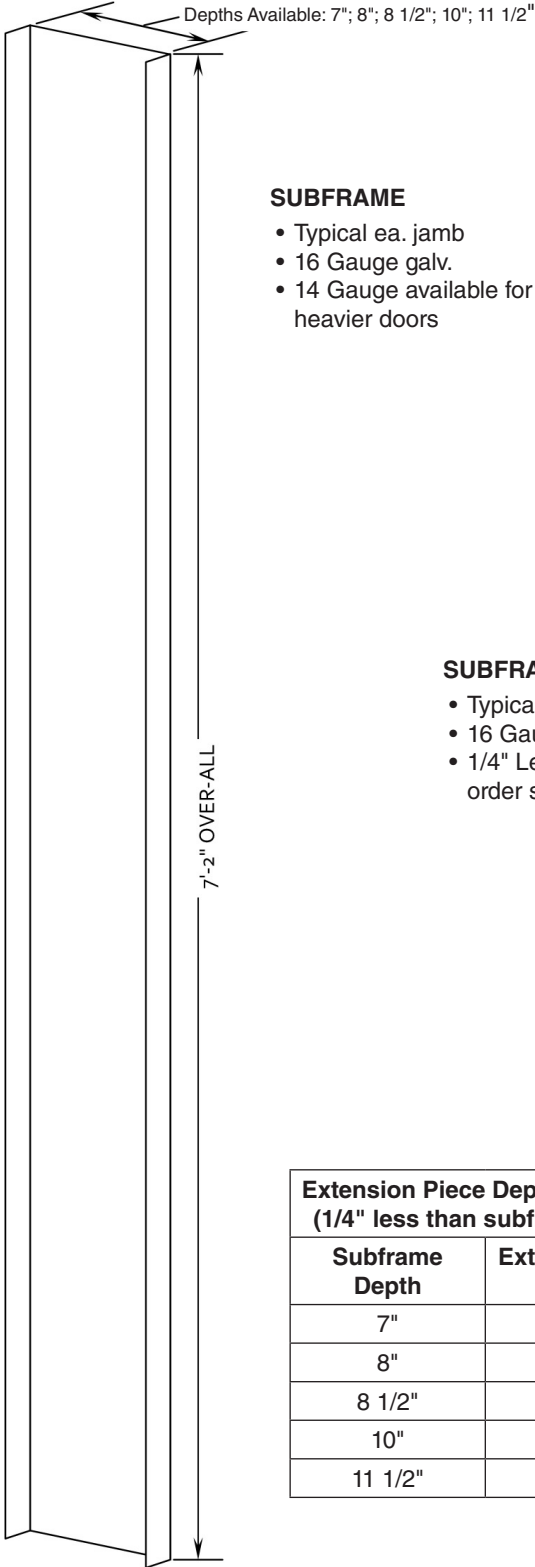

- SUBFRAME**
- Typical ea. jamb
  - 16 Gauge galv.
  - 14 Gauge available for heavier doors

- SUBFRAME EXTENSION**
- Typical ea. jamb
  - 16 Gauge galv.
  - 1/4" Less than subframe order size

Extension Piece Depths Available (1/4" less than subframe depth)	
Subframe Depth	Extension Piece Depth
7"	6 3/4"
8"	7 3/4"
8 1/2"	8 1/4"
10"	9 3/4"
11 1/2"	11 1/4"

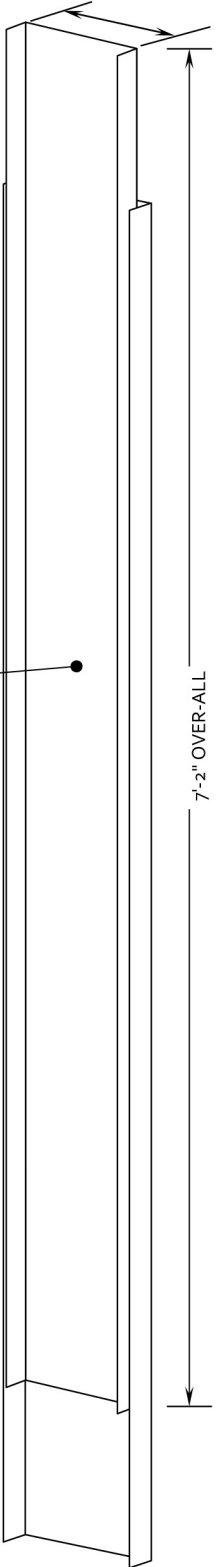

# FLUSH SUBFRAME ATTACHMENT DETAILS

## Flush-Mount Subframe Attachment Typical @ Header and Jambs

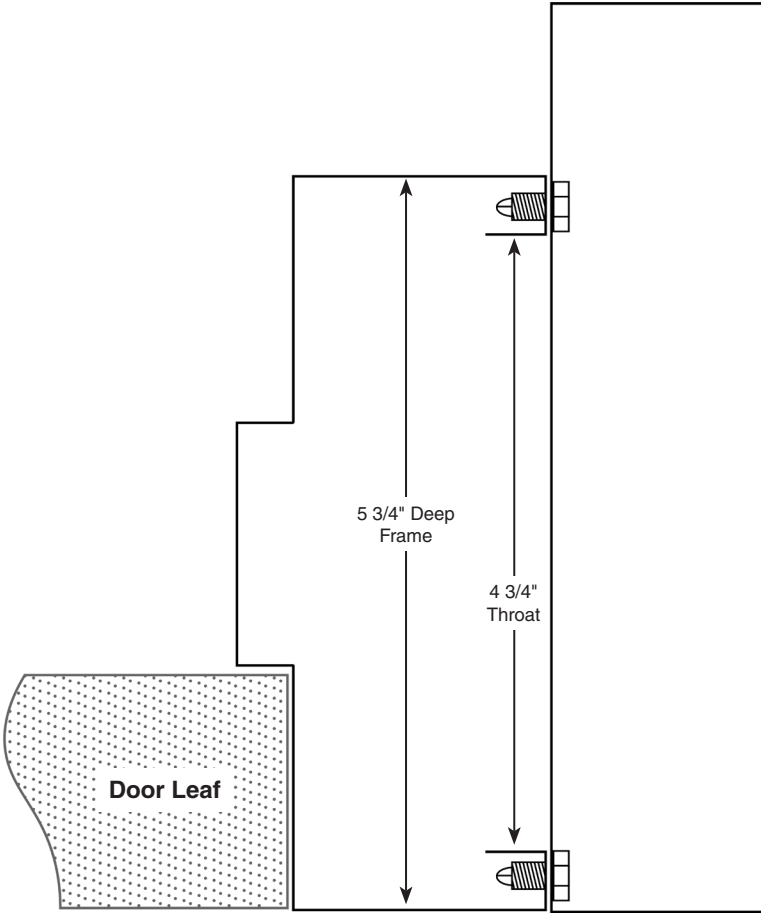

# OFFSET SUBFRAME ATTACHMENT DETAILS

## Offset C-Channel Subframe Using EXPI-Anchor

### Test Lab Final Report

<b>Test Number</b>	<b>T-1136</b>
<b>Lab Tech</b>	<b>K. Bishop</b>
<b>Initiator:</b>	<b>K. Roeper</b>

**Test A: Fit / Function check - no lock hardware installed.**

Door hung with std weight template butt hinges in opening to check for function and fit (clearance) issues.

No issues were noted.

**Test B: Accelerated Cycle Test SDI 250.5 - Level B 500,000 cycles**

Unit checked periodically throughout cycle testing for sag, metal fatigue, separation of seams, fastener failure. No issues noted during or after completion of cycle testing.

Full copy of 4/10/2000 Physical Endurance Test available upon request with non-disclosure agreement signed. (Optional offering).

See Offset Installation Instruction for details.

### OFFSET SUBFRAME ATTACHMENT

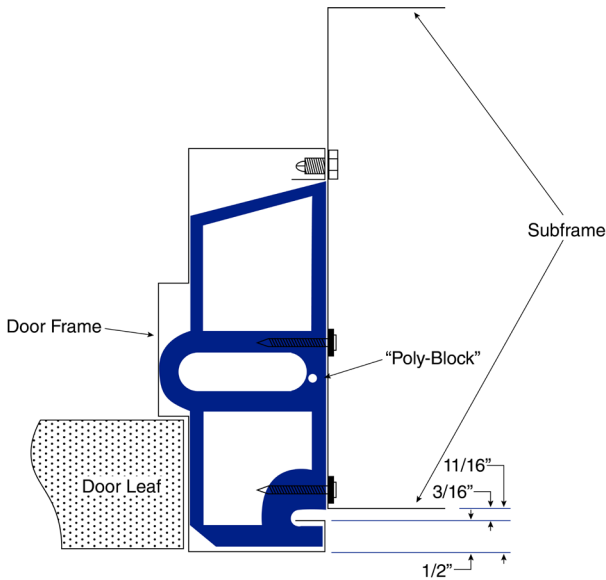

### OFFSET SUBFRAME

The Offset C-Channel allows for the self-flashing system with the wall panel tucked behind the front face of the frame. No jamb trim is required.

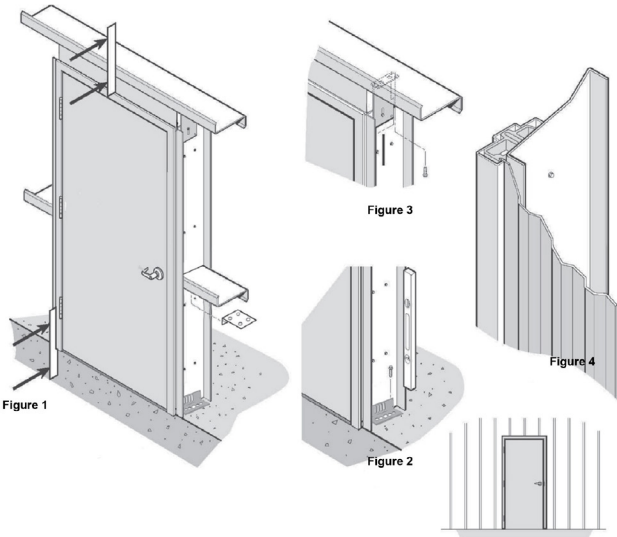
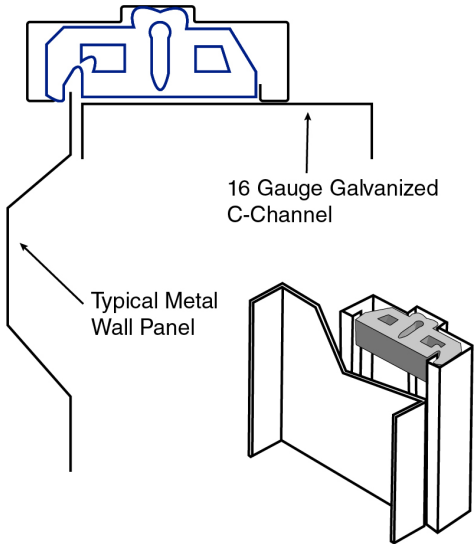

# LATCHGUARD DETAILS

**Stainless Steel Latchguard**  
**Included in Standard EXPI-DOOR Package**



**LATCHGUARD FOR  
CYLINDRICAL (BORED)  
LOCKSETS**

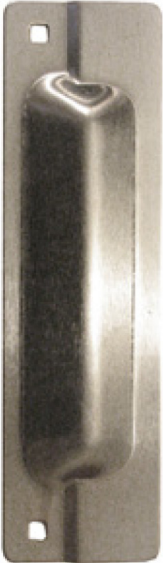

**LATCHGUARD FOR  
MORTISE LOCKSETS**

**SPECIALTY CARRIAGE SEX NUT/BOLT  
W/ ALLEN DRIVERS**

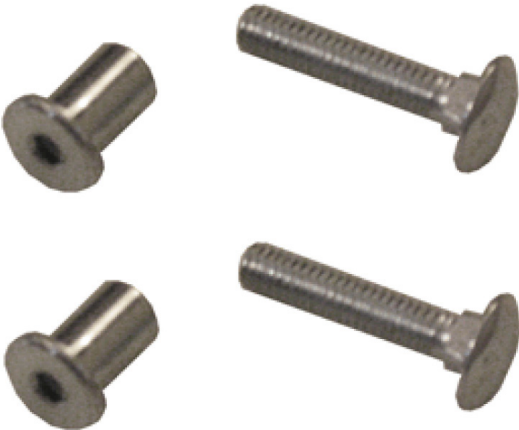

# STANDARD-DUTY CLOSER

## SC61A x 689

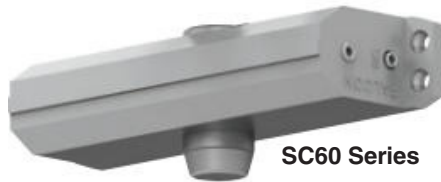

SC60 Series

The "1" in the part number indicates that it is a multi-sized closer, adjustable from 1 through 5.

When you need a dependable closer for a light to medium-duty application, the Falcon SC60 Series gets the job done. Designed for interior use with an aluminum storefront, the SC60 Series offers ANSI Grade 1 durability backed by a ten-year warranty. Most common hole pattern in the industry for versatile use and easy retrofit.

### Listings and Certifications

The Falcon SC60 Series is UL approved and compliant with the UL 10C and UBC 7-2 (1997) fire test. Additionally, the SC61A is designed to meet the American Disabilities Act (ADA) and ANSI A117.1. The SC60 Series is ANSI/BHMA A156.4, Grade 1 certified.

### Standard Features

- Meets ANSI A117.1
- ANSI/BHMA A156.4, Grade 1
- UL Listed
- 1 3/8" diameter piston
- Closer mounts hinge side, top jamb or parallel arm when either the Rw/PA or Hw/PA arm is specified
- Adjustable sizes 1-5 (SC61A)
- Single piece cast aluminum body
- Staked valves
- Non-handed for left or right swinging doors
- Separate adjustable general speed, latch speed, and backcheck
- Heat-treated steel piston
- Heat-treated pinion
- UL 10C approved fluid
- Universal screw pack
- 10-Year Limited Warranty

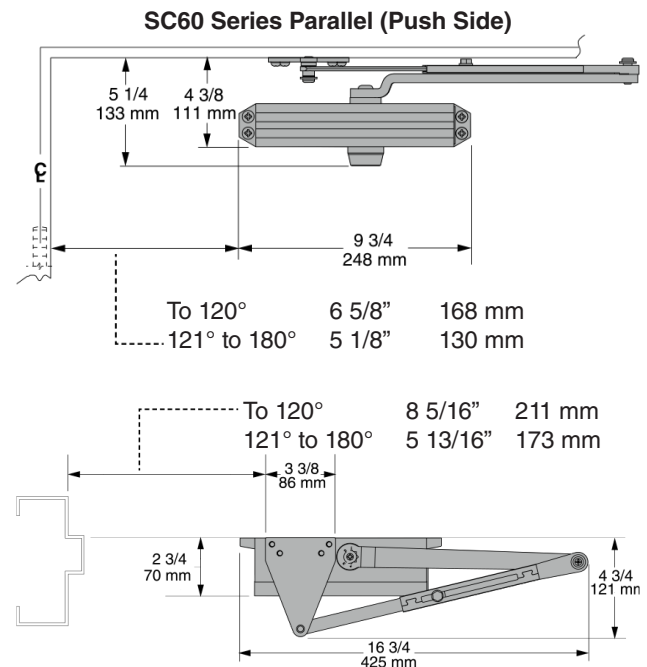

### Complete Installed Appearance - Side View

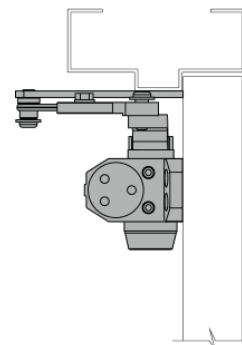

# MODERATE-DUTY CLOSER

## SC81A x 689



The "1" in the part number indicates that it is a multi-sized closer, adjustable from 1 through 6.

Medium-duty applications like retail storefronts, cafes and clinics that need a closer that makes door operation smooth and secure. The Falcon SC80 Series brings ANSI Grade 1 durability and reliable performance to interior and exterior aluminum storefronts. An adjustable design ensures flexible installation and ADA compliance.

### Listings and Certifications

The Falcon SC81A is UL approved and compliant with the UL 10C and UBC 7-2 (1997) fire test. Additionally, the SC81A is designed to meet the American Disabilities Act (ADA) and ANSI A117.1. The SC81A is ANSI/BHMA A156.4, Grade 1 certified.

### Standard Features

- Meets ANSI A117.1
- ANSI/BHMA A156.4, Grade 1
- UL Listed
- 1 1/4" diameter piston
- Closer mounts hinge side, top jamb or parallel arm when either the Rw/PA or Hw/PA arm is specified
- Adjustable sizes 1-6
- Single piece cast aluminum body
- Non-handed for left or right swinging doors
- Separate adjustable general speed, latch speed, and backcheck
- Heat-treated steel piston
- Heat-treated pinion
- Cover is high-impact UL Listed fire-retardant plastic that meets UL 10C and UBC 7-2 (1997) fire test
- UL 10C approved fluid
- Universal screw pack
- 10-Year Limited Warranty

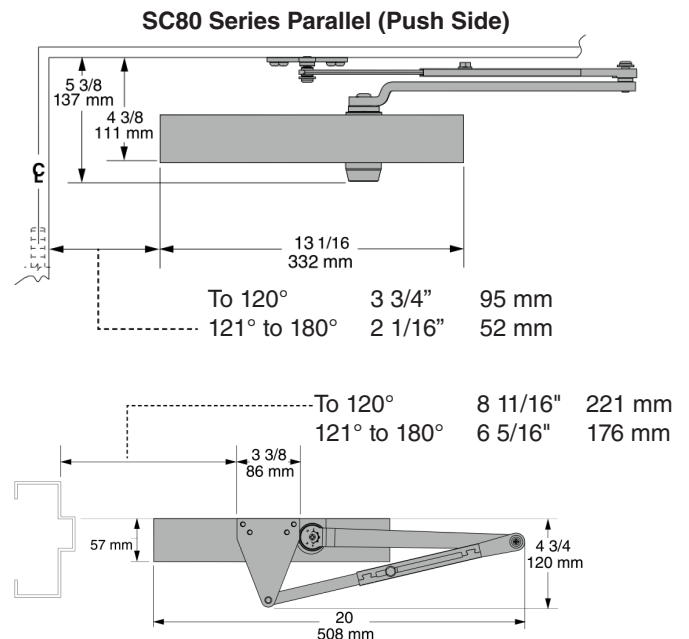

### Complete Installed Appearance - Side View

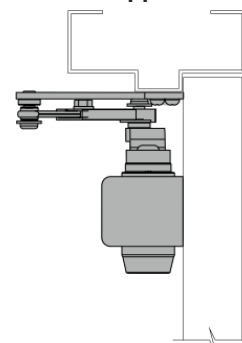



# HEAVY-DUTY CLOSER

## SC71A x 689



The "1" in the part number indicates that it is a multi-sized closer, adjustable from 1 through 6.

Falcon SC70 Series heavy-duty closers are built for busy commercial applications that demand reliable door control and easy maintenance. Designed for use with aluminum storefronts, SC70 Series closers are ANSI Grade 1, ADA compliant and deliver tough performance. Choose the SC70 for interior or exterior doors in retail shops, restaurants, and small offices

### Listings and Certifications

The Falcon SC71A is UL approved and compliant with the UL 10C and UBC 7-2 (1997) fire test. Additionally, the SC71A is rated ANSI/BHMA A156.4, Grade 1 and designed to meet the American Disabilities Act (ADA) and ANSI A117.1.

### Standard Features

- Meets ANSI A117.1
- ANSI/BHMA A156.4, Grade 1
- UL Listed
- 1 1/2" diameter piston
- Closer mounts hinge side, top jamb or parallel arm when either the Rw/PA or Hw/PA arm is specified
- Adjustable sizes 1-6
- Single piece cast aluminum body
- Staked valves
- Non-handed for left or right swinging doors
- Fast and easy installation
- Separate adjustable general speed, latch speed, and backcheck
- Heat-treated forged steel piston
- Double heat-treated pinion
- Cover is high-impact UL Listed fire-retardant plastic that meets UL 10C and UBC 7-2 (1997) fire test
- UL 10C approved fluid
- Universal screw pack
- 10-Year Limited Warranty

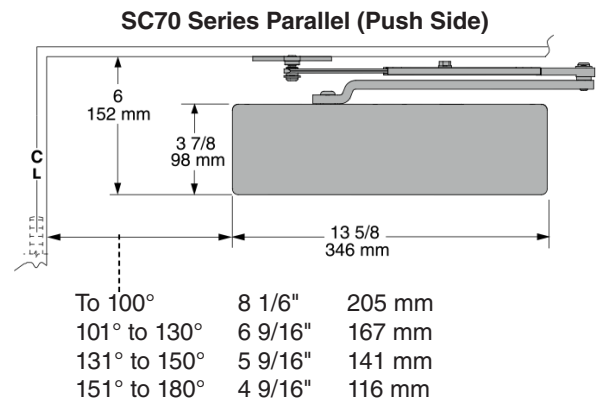

### Complete Installed Appearance - Side View

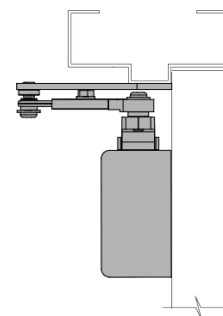

**Butt Hinges** should not exceed 5" (127mm) in width  
**Auxiliary Stop** is recommended at hold-open point or where a door cannot swing 180°  
**Top Rail** less than 6" (152mm) measured from stop requires plate SC70-18PA  
**Delayed Action** adds suffix "DEL" to selected cylinder (ex. SC70 DEL). Delays closing from maximum opening to approx. 70° with adjustable delay time.

## CRASH CHAIN DETAILS

### Hager 300D

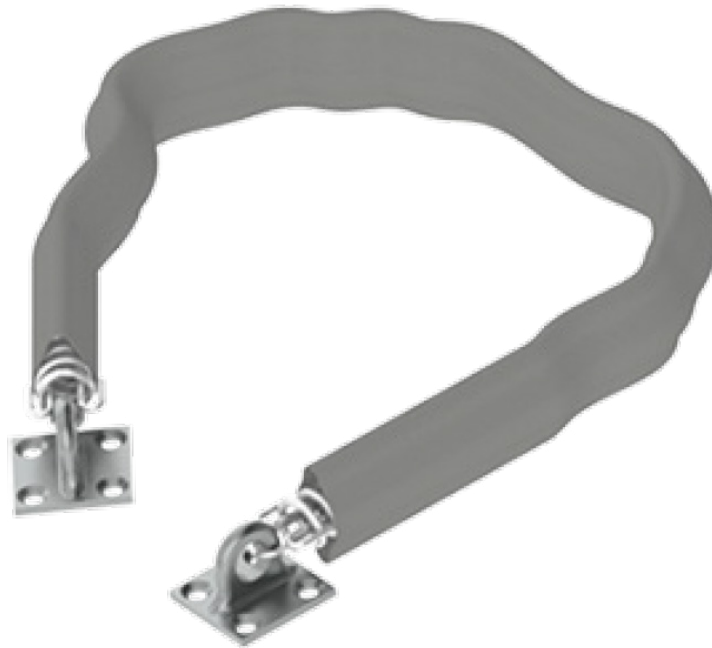

Use alone or in conjunction with any surface-mount closer.

#### Features:

- Specially designed for full-size exterior doors
- Tear-resistant, grey EPDM rubber cover with UV protection
- Heavy-duty compression spring assembled to both ends of chain and end brackets
- Packed with sheet metal screws
- Chrome plated zinc alloy brackets with solid, welded steel chain
- 440 lb. load strength

#### Attachment:

Pre-measured and installed w/ #18 x 1" #2 Phillips head screws

Mounts to door stop (soffit) surface of door frame and to the door leaf, by connecting through the internal closer reinforcement

## STANDARD LOCK DETAILS - GRADE 2

### Grade 2 Entry Lever

#### Included in Standard EXPI-DOOR Package

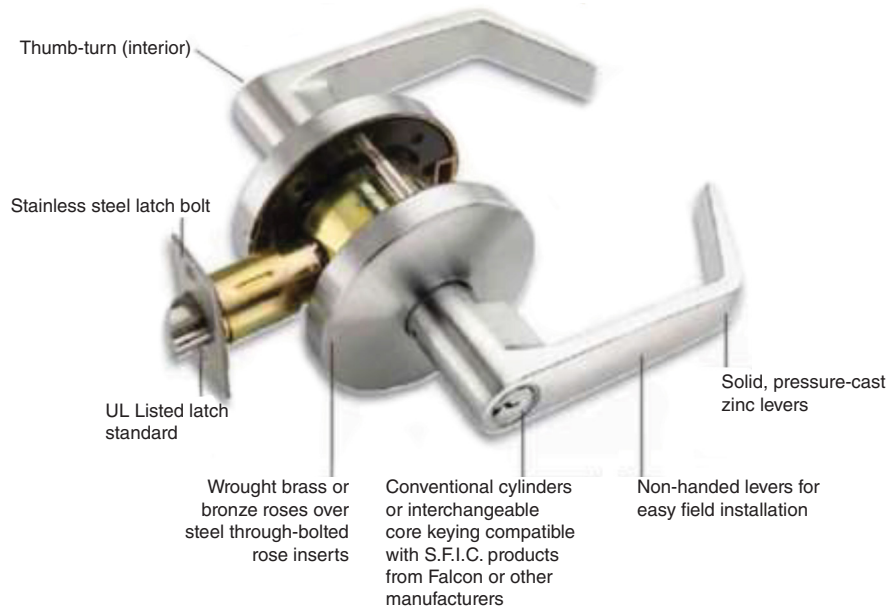

### SPECIFICATIONS

- Falcon Grade 2 entry lever, keyed
- Bored/Cylindrical
- 2 3/4" Back-set
- Brushed Chromium (US26D) finish
- Stainless steel latchbolt w/ 1/2" throw, deadlocking
- Steel lock chassis, zinc dichromated for corrosion resistance
- Fits standard Gov. 161, or 61L prep w/thru-bolting thru door
- Solid cast levers
- Independent lever return springs
- Strike 1 1/4" x 4 7/8" ANSI
- Schlage "C" keyway 6-pin cylinder
- Meets ANSI A117.1 Accessibility (ADA) Code
- Meets ANSI A156.2 Series 4000, Grade 2
- UL Listed up to "A" Label (3-Hour) single swing doors
- (2) Year Limited Warranty

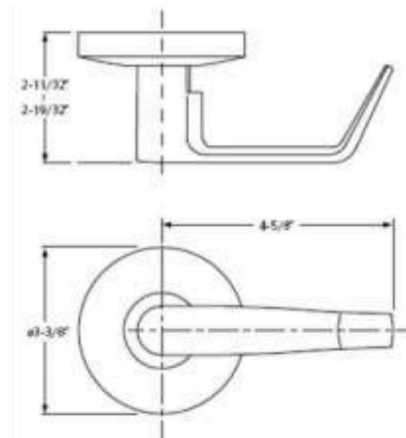

#### Optional Keyway:

Small Format  
Interchangeable Core  
To accept BEST brand primarily



Dane shown

# STANDARD LOCK DETAILS - GRADE 1

## Grade 1 Entry Lever

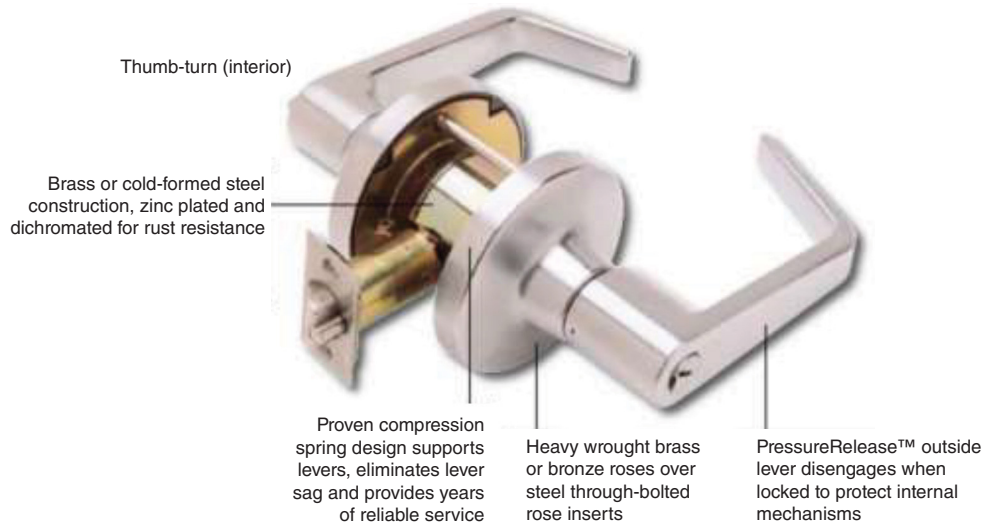

## SPECIFICATIONS

- Falcon Grade 1 Entry Lever, keyed
- Bored/Cylindrical
- 2 3/4" Back-set
- Brushed Chromium (US26D) finish
- Stainless steel latchbolt w/ 1/2" throw, deadlocking
- Steel lock chassis, zinc dichromated for corrosion resistance
- Fits standard Gov. 161, or 61L prep w/thru-bolting thru door
- Solid cast levers
- Independent lever return springs
- Strike 1 1/4" x 4 7/8" ANSI
- Schlage "C" keyway 6-pin cylinder
- Meets ANSI A117.1 Accessibility (ADA) Code
- Meets ANSI A156.2 Series 4000, Grade 1
- UL Listed up to "A" Label (3-Hour) single swing doors
- (5) Year Limited Warranty

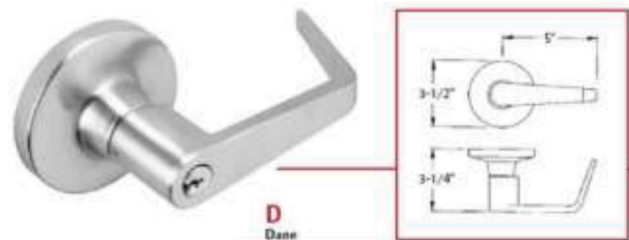

### Optional Keyway:

Small Format Interchangeable Core (S.F.I.C.)  
To accept BEST brand primarily



## DEFAULT GRADE 1 STANDARD-DUTY EXIT DEVICE DETAILS

### Exit Device (Panic) with Key-In-Lever Trim Hager 4701-ALM x 47KE-ALM



Available from stock for 2'-5" door size up to 3'0" door size.  
**Panic Devices for 4'0" doors are special order.**



Key-in-lever exterior trim with 6-pin conventional Schlage C keyway

*All locks, per order, shall be keyed alike by EXPI-DOOR prior to shipping.\*\**

*\*\*All locks on one order shall be keyed alike by EXPI-DOOR, unless we are instructed otherwise at time of order processing to do one of the following:*

1. Key all locks differently but with 2 master keys per order
2. Key differently or alike in specific groups, at which point a keying schedule must be provided to EXPI-DOOR.



#### OPTIONAL (extended leatimes)

Lever on escutcheon trim and keyed mortise cylinder with Schlage \*Conventional Core 6-Pin C

- Default lock function: ANSI "08", key locks, unlocks trim
- Escutcheon: 2 5/8" x 8"
- Finish: "ALM" (Powder-coated aluminum flat bar & lever trim ANSI US28 / BHMA 689)
- Requires mortise cylinder (included)
- Projection: 2 3/4"

*\*Available from stock, OPTIONAL mortise cylinder with S.F.I.C. (Small Format Interchangeable Core) BEST Access brand compatible. One (1) control key per order and two (2) operating cut keys per door. Keyed alike by default.*

### CERTIFICATIONS

- ANSI A156.3-2001, Grade 1 standard-duty commercial
- UL/cUL Listed for up to 3 hours for "A" label single doors
- UL10C/UBC 7-2 (1997) positive pressure rated
- UL10B neutral pressure rated
- Hex dogging feature standard on non-fire-rated doors
- Warnock-Hersey listed
- ANSI A117.1 for accessible buildings and facilities (handicap)
- UL305 listed for panic hardware
- Member BHMA
- 5-Year Warranty

## FORMATTED, INTERCHANGEABLE CORE (S.F.I.C.) INFORMATION

Mortise or rim cylinder housing with Figure-8 S.F.I.C. Cylinder Core in Falcon "A" Keyway (comparable to BEST's most common keyway) - Used for mortise/rim locks, mortise exit devices, cylindrical dogging for any exit device (add option), and most auxiliary hardware.

Provided with:

- One (1) control key for core removal from lockset.
- Two (2) operating keys to lock/unlock the lever or device.

Permanent cores provided by the manufacturer only and sold directly to the end-user.

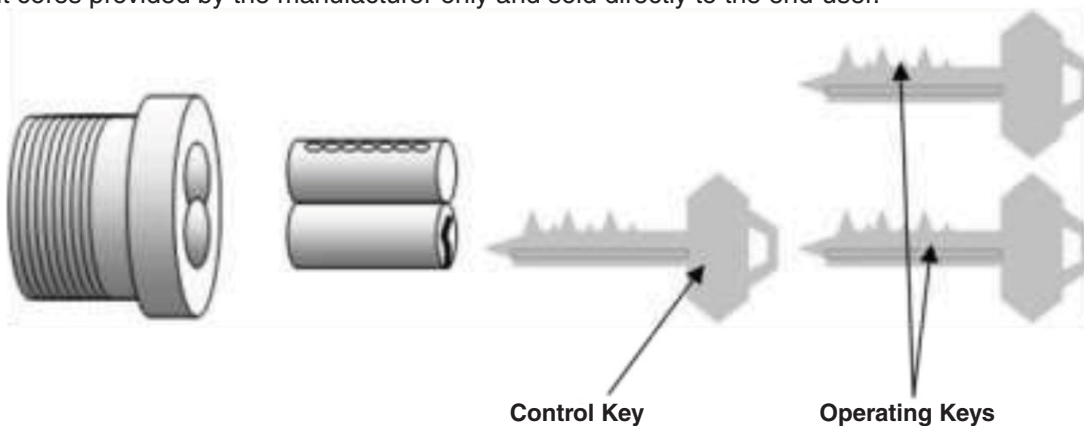
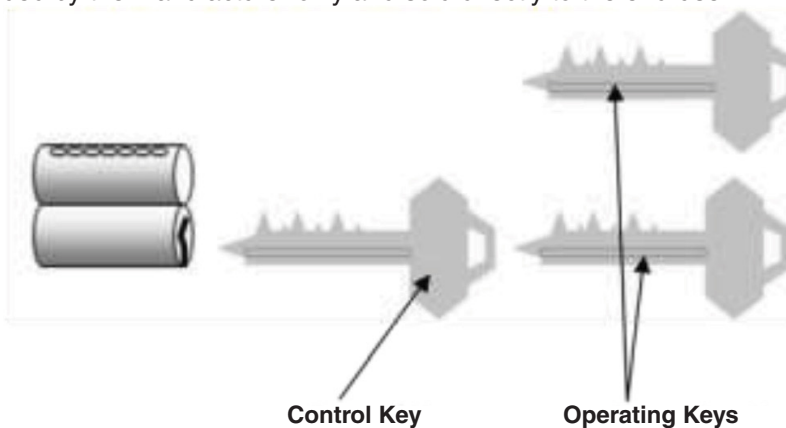

Figure-8 S.F.I.C. Cylinder Core in Falcon "A" keyway (comparable to BEST's most common keyway) - Used for cylindrical locks and key-in-lever exit device trim.

Provided with:

- One (1) control key for core removal from lockset
- Two (2) operating keys to lock/unlock the lever or device

Permanent cores provided by the manufacturer only and sold directly to the end-user.



Housings and I.C. keyways by Schlage or Falcon. Must specify when ordering if "small format" or "full size" cores are needed.

# MORTISE LEVER LOCK DETAILS

## Grade 1 Mortise Entry Lever

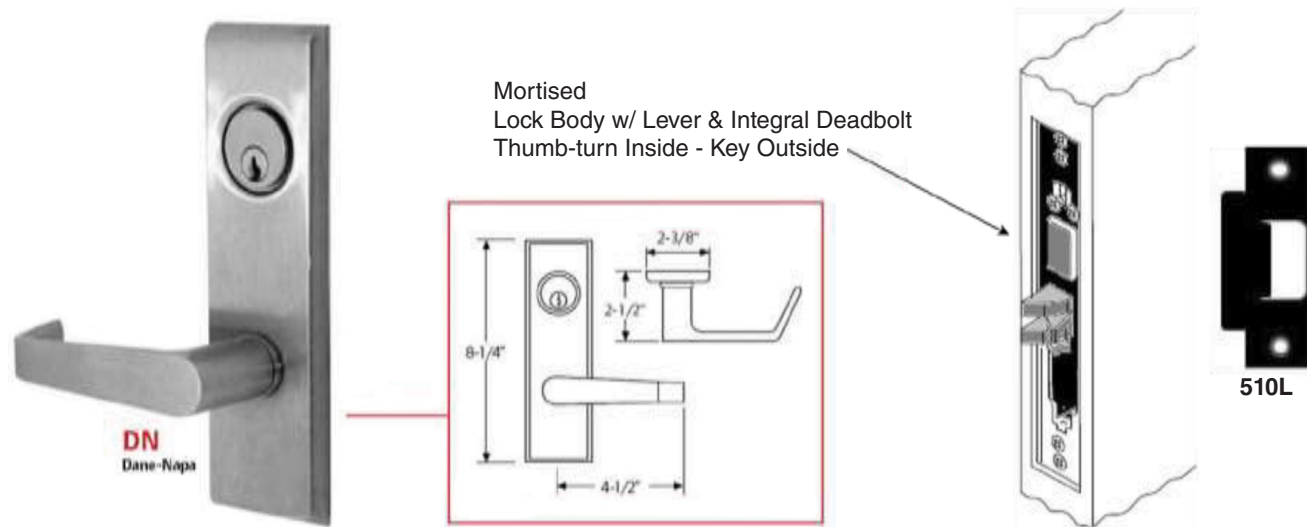

Catalog Number	Function	Description	ANSI No. & Grade
M571		<b>Dormitory Lock</b> Latch bolt by knobs/levers except when outside knob/lever is locked by projecting deadbolt. Key outside retracts deadbolt and unlocks outside knob/lever. Rotating inside knob/lever retracts both bolts.	F13-1 F13-2

- ANSI A156.13 Series 2000, Grade 1
- UL Listed for "A" Label (3-Hour) fire doors
- 2 3/4" Back-set / field reversible lock-body
- Brushed Chromium (US26D) finish
- Brass / anti-friction constructed deadbolt w/ 1" throw
- Lever retracts deadbolt from thumb-turn side for life-safety compliance
- Fits Standard Gov. 86 & 86E prep w/ thru-bolting thru door
- Cases are cold-rolled formed steel 0.090 thick - zinc
- Solid forged brass handles and escutcheons
- Strike 1 1/4" x 4 7/8" ANSI
- Standard Keyway: Schlage "C" keyway 6-pin cylinder / S.F.I.C. is OPTION only
- 10 Year Warranty

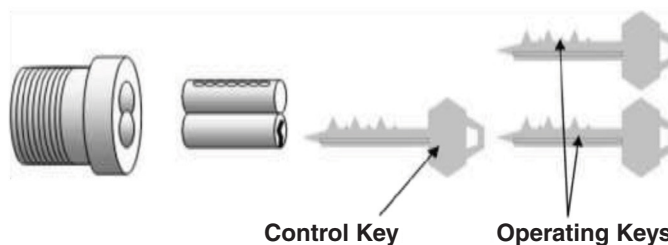

### Optional Keyway

Mortise cylinder housing with Figure-8 S.F.I.C. cylinder core in Falcon "A" keyway (comparable to BEST's most common keyway).

Provided with:

- (1) control key for core removal from lockset
- (2) operating keys to lock / unlock the lever or device

To accept BEST brand primarily

# HINGE DETAILS

## Standard Hinges

1 1/2 Pair Per Single Door

3 Pair Per Double Door



- Satin Chromium Finish over steel (BHMA 652)
- 4.5" x 4.5" (114 mm x 114 mm)
- 0.134" Gauge standard weight
- Non-removable pin
- 5-Knuckle w/ button tip & plug
- Ball bearings
- ANSI A8112

Heavy-weight hinges available upon request



- OPTIONAL**
- ANSI A156.1
  - Stainless steel material and US32D finish
  - 4.5" x 4.5" (114mm x 114mm)
  - 0.134" Gauge standard weight
  - Non-removable pin
  - ANSI A5112



- OPTIONAL**  
**HAGER HINGE CO.**  
**Model # BB1191**
- ANSI A156.1
  - Brass leaf & SS pin
  - 4.5" x 4.5" (114mm x 114mm)
  - 0.134" Gauge standard weight
  - Non-removable pin
  - ANSI A2112



- OPTIONAL**  
**HAGER HINGE CO.**  
**Model # BB1199**
- ANSI A156.1-2000
  - Stainless steel leaf & SS pin
  - 4.5" x 4.5" (114mm x 114mm)
  - 0.180" Gauge heavy weight
  - Non-removable pin
  - ANSI A5111



## STANDARD FULL-SURFACE CONTINUOUS HINGE

Optional for all doors, but **DEFAULT** for Series DB 4/0 x 7/0 Door Systems

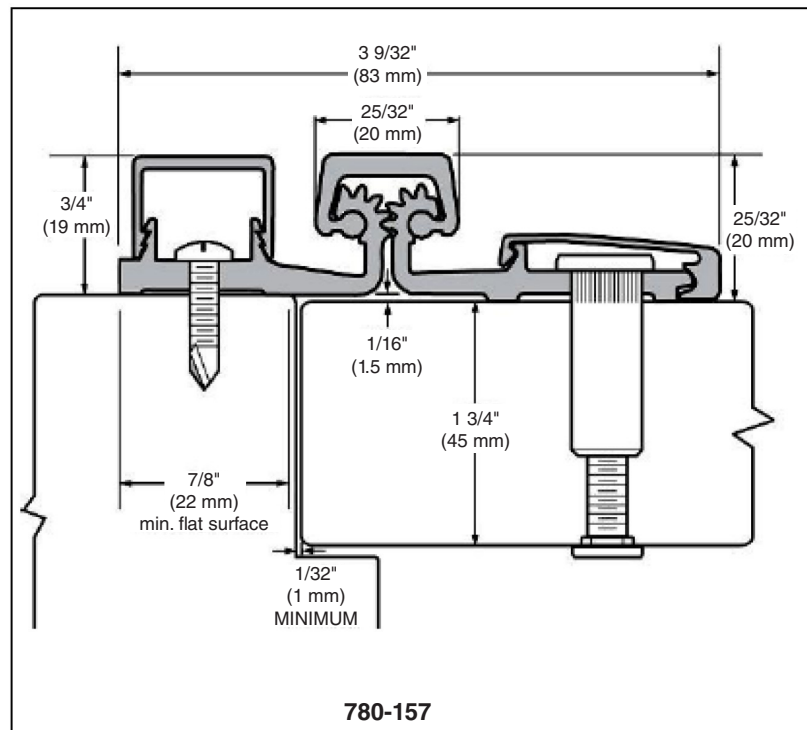

### Product Specifications

**Fasteners:**

- Standard #12-24 x 11/16" self-drilling pan head machine screw.
- 1/4" - 20 thru bolts for 1-3/4" doors.

**Length Options:**

- Length to be ordered should be one inch LDH (Less Door Height).

**Door Reinforcement:**

- None required.

**Frame Reinforcement:**

- None required to 200 lbs. Heavier weight use 16-gauge reinforcing channel welded-in behind face.

**Fire-Rating:**

- Up to 3 hour metal and 90 minute wood composite (with fire-studs).
- When ordering, must specify if UL stamp is required.

**Warranty:**

- All Roton products have a lifetime warranty. Electronic transfer hinges shall carry a one-year warranty.

**Material:**

- Aluminum 6063T6.

# STANDARD U-SWEEP

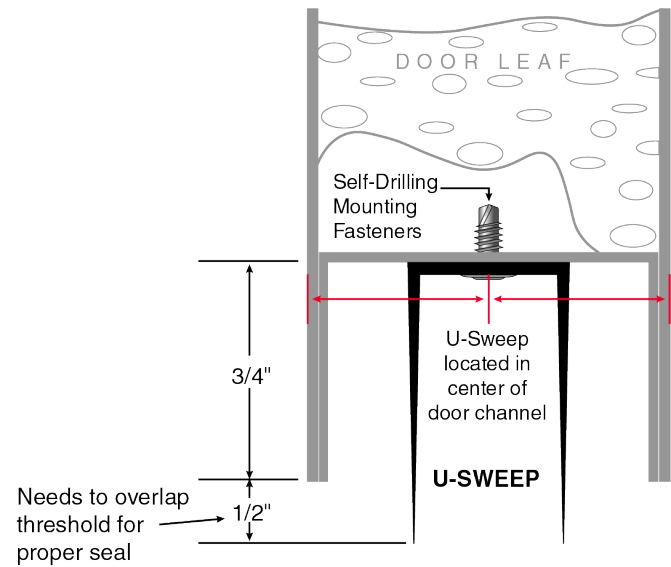

## DESCRIPTION:

- Dual-finger door shoe, NGP #331 (or equal)
- Rigid black polypropylene top with flexible TPV fins
- Designed for hollow metal doors with inverted bottom channel
- Installs at center-line of door leaf (as pictured)

## PERIMETER WEATHERSTRIPPING

### Self-Adhesive Silicone Fire and Smoke Seal

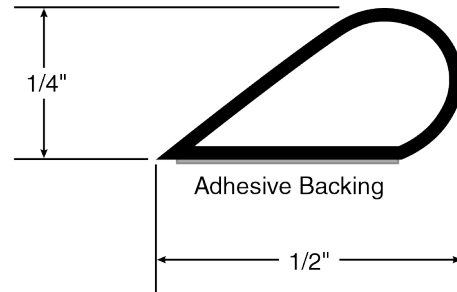

#### DESCRIPTION:

- Synthetic rubber polymer: Siloxane
- Self-adhesive "C" Charcoal (Black) material
- Flame resistant
- Excellent flexibility and memory
- Excellent resistance to ozone, UV, and aging

#### CERTIFICATIONS:

- ANSI/UL10C, ANSI/UL 1784 Category 'H': Smoke & draft control
- ASTM E283: Air Infiltration/Leakage
- NFPA 80 & 252 positive pressure
- CAN/ULC-S104 and ANSI/UL10B: 90 minute fire resistant
- ANSI/BHMA A156.22 gasketing and edge seal systems
- End use temperature range of adhesive, long term exposure -30°F up to 250°F
- Modified acrylic pressure-sensitive adhesive protected by release liner
- BHMA certified to ANSI/BHMA A156.22 performance tests for heat, cold and air filtration.
- Resistant to aging, weathering, UV radiation, moisture, detergent

## STANDARD A.D.A COMPLIANT THRESHOLD

All thresholds shall be fastened to the base of each jamb on the interior door side rabbet and the exterior door side rabbet directly into threshold “flutes” located on the underside of the threshold. These flutes run the entire length of each threshold. Thresholds shall be 5-3/4" wide and U-notched.

 **ADA COMPLIANT.** Barrier-free thresholds meet the requirements of the ADA Standard for Accessible Design and ICC/ANSI A117.1 Accessible and Usable Buildings and Facilities.

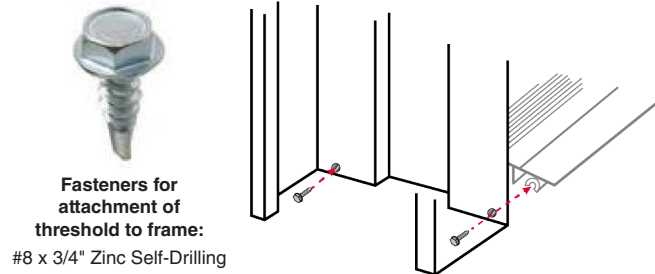

### Top & End View - 36" Threshold: Number of Anchor Holes for 3' Threshold shall be (4)

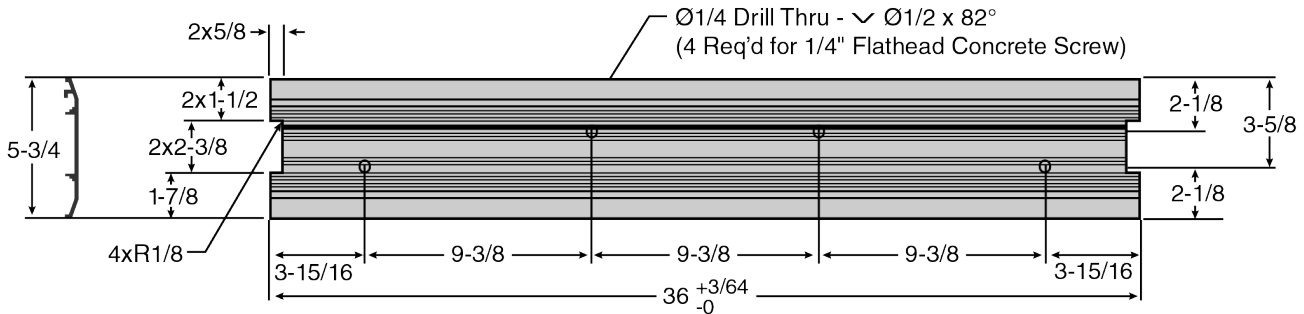

For anchorage to the concrete floor, thresholds shall be produced with pre-punched, countersunk holes to accept 1/4" diameter concrete sleeve anchors (provided by EXPI-DOOR). Three-foot single door system thresholds shall consist of four (4) countersunk bores, and shall be “staggered” across the length of the Threshold.

Fastening the threshold to the frame in the factory is a bonus advantage for several reasons.

1. EXPI-DOOR's threshold is pre-notched at each end to fit around the door jamb's soffit portion of the frame.
2. EXPI-DOOR's threshold is pre-attached to each jamb, thus ensuring proper alignment of door w/in frame.
3. EXPI-DOOR's threshold, because it is attached at the factory, assures strong reinforcement at the base of the frame, as opposed to older methods of securing the frame at the base temporarily.

Our pre-attachment process is far superior to the common process in place for some of our competitors, as well as being the standard for many years for “knock-down” door systems.

**Floor Anchors**  
1/4" Hole Size x 1-1/2" Embedment  
Actual Anchor: 1/4" x 2"

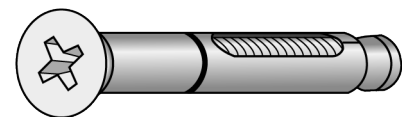
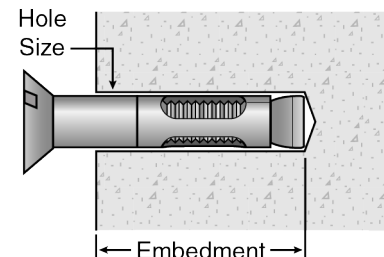

# KICK PLATE DETAILS

8" High x 2" Less Door Width (LDW) x 0.050" Thick  
Stainless Steel w/TEK Fasteners for Attachment

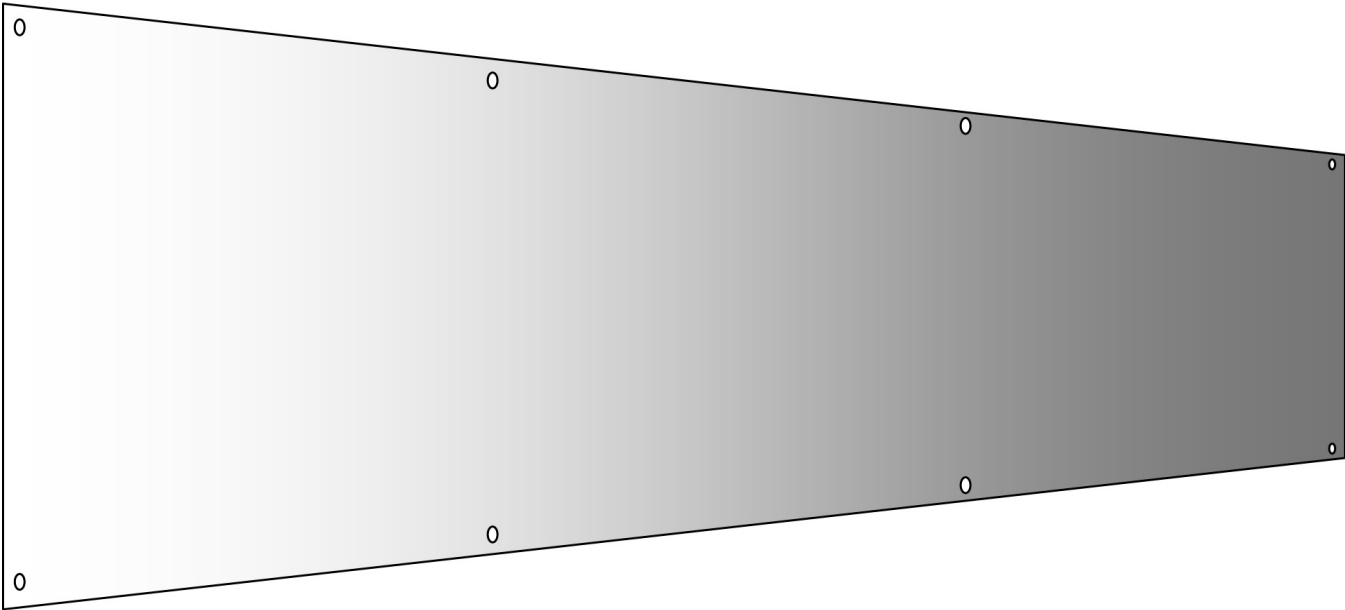

- ANSI A156.6
- Stainless steel material and US32D finish
- 0.050" Thick, 18 gauge

# DOUBLE DOOR DETAILS

## Single Active Door System

- W/ surface bolts - EXPI Designation: 6070-1
- W/ flush bolts - EXPI Designation: 6070-1FB

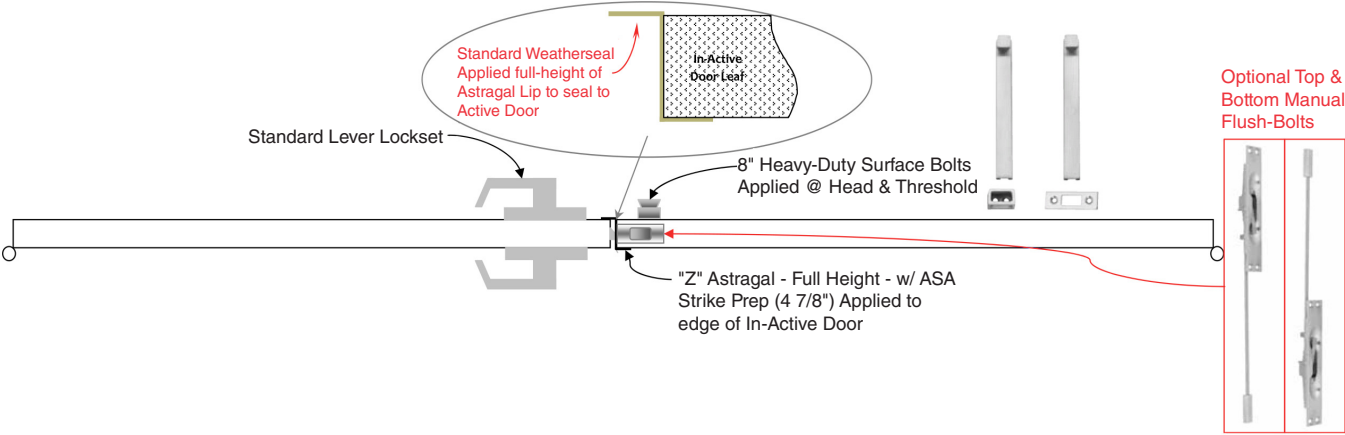

## Double Active Door System

EXPI Designation: 6070-2

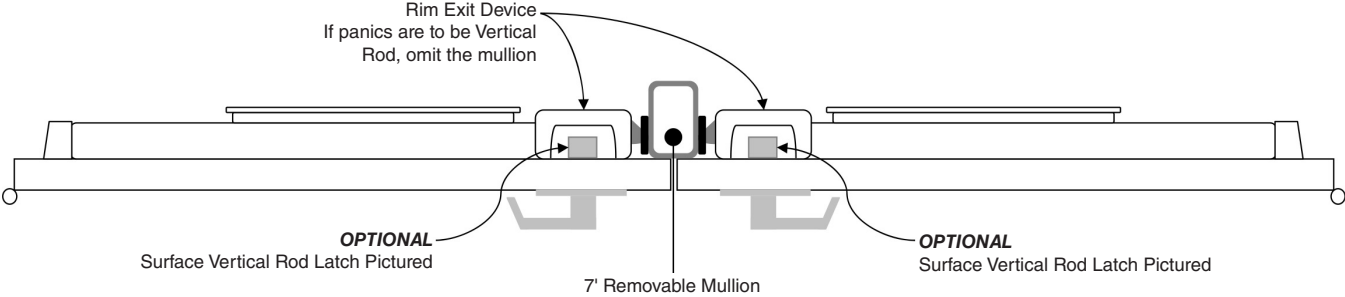

### Seal Type @ Pairs w/ Rim Panics & Mullion

